

VUE: Flanged through valve, PN 16/10

How energy efficiency is improved

Accurate control with high reliability.

Areas of application

Continuous control of cold/hot water, air and low-pressure steam up to 115 °C in closed networks¹⁾. Water quality as per VDI 2035. Assembly with AVP 242 to AVP 244 actuators as a regulating unit.

Features

- Nominal pressure 16 bar
- Control valve contains no silicone grease; painted black
- Nominal diameters DN15 to DN150
- Equal-percentage characteristic in the case of F300
- Linear characteristic in the case of F200 with increased k_{vs} value
- With the spindle retracted, the valve is closed
- Closes against the pressure DN15 to DN150 or with the pressure DN15 to DN50

Technical description

- Valve with flange connection as per EN 1092-2, Form B, raised face, for PN16 and PN10
- Valve body and seat in cast iron
- Stainless steel spindle
- Brass plug in nominal diameters DN15 to DN50, with glass-fibre-reinforced PTFE sealing ring
- Brass plug in nominal diameters DN65 to DN150, metal-on-metal seal
- Stuffing box made of brass with EPDM wiper ring and double O-ring seal



T10990



Y07544

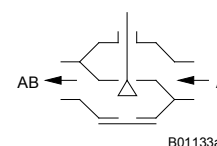

B01133a

Type	Nominal diameter DN	Connection PN	k_{vs} value m^3/h	Weight kg
VUE 015 F350	15	16 / 10	0.4	3.2
VUE 015 F340	15	16 / 10	0.63	3.2
VUE 015 F330	15	16 / 10	1.0	3.2
VUE 015 F320	15	16 / 10	1.6	3.2
VUE 015 F310	15	16 / 10	2.5	3.2
VUE 015 F300	15	16 / 10	4.0	3.2
VUE 020 F300	20	16 / 10	6.3	4.1
VUE 025 F300	25	16 / 10	10	4.7
VUE 032 F300	32	16 / 10	16	7.3
VUE 040 F300	40	16 / 10	22	8.6
VUE 050 F300	50	16 / 10	28	11.2
VUE 050 F200	50	16 / 10	40	11.2
VUE 065 F300	65	16 / 10	49	17.3
VUE 065 F200	65	16 / 10	63	17.3
VUE 080 F300	80	16 / 10	78	22.9
VUE 080 F200	80	16 / 10	100	22.9
VUE 100 F300	100	16 / 10	124	33.0
VUE 100 F200	100	16 / 10	160	33.0
VUE 125 F300	125	16 / 10	200	48.0
VUE 125 F200	125	16 / 10	240	48.0
VUE 150 F300	150	16 / 10	300	68.0
VUE 150 F200	150	16 / 10	320	68.0

Operating temperature	-10...150 °C ²⁾	Dimension drawing	DN 15...50	M10437
Operating pressure	up to 120 °C, 16 bar up to 130 °C, 13 bar up to 150 °C, 10 bar		DN 50...150	M10439
Valve characteristic F200	linear	Fitting instructions		
F300	equal-percentage	Valve	DN 15...50	MV 506008
Valve control ratio	> 50:1	Valve	DN 65...150	MV 505964
Stuffing box	2 O-rings, EPDM	Assembly	AVP 242 F001	MV 506041
Leakage rate at max. Δp_s	$\leq 0.05\%$ of k_{vs} value	Assembly	AVP 242 F021	MV 506012
Valve stroke DN 15...50	8 mm	Assembly	AVP 243 / 244	MV 506013
DN 65...80	20 mm	Material declaration		MD 76.115
DN 100...150	40 mm			

1) Air humidity must not exceed 75%

2) At temperatures below 0 °C, use the stuffing box heater; at temperatures above 100 °C, use the temperature adaptor (accessory).

Accessories

- 0372240 001*** Manual adjuster for valves with 8 mm stroke; MV 505813
- 0372249 001*** Adaptor required when temperature of medium >100 °C up to 130 °C (also recommended at < 10 °C) from DN 15 to DN 50, MV 505932
- 0372249 002*** Adaptor required when temperature of medium >130 °C up to 150 °C, from DN 15 to DN 50, MV 505932
- 0372336 180** Adaptor required when temperature of medium. >130 °C / >150 °C from DN 65, MV 505902
- 0378284 100*** Stuffing box heater, 230 V~; 15 W, for media below 0°C, DN 15...150, MV 505978
- 0378284 102*** Stuffing box heater, 24 V~; 15 W, for media below 0°C, DN 15...150, MV 505978
- 0378368 001** Complete replacement stuffing box for DN 15 to DN 50
- 0378369 001** Complete replacement stuffing box for DN 65 to DN 150

*) Dimension drawing or wiring diagram available under the same number

Warranty The technical data and pressure differences indicated here are only applicable in combination with Sauter actuators. Any warranty shall lapse if actuators from other manufacturers are used.

Combination of VUE, PN 16/10 with pneumatic drive AVP 242

Drive:	AVP 242 F001		
Perm. press. P_{stat} :	≤ 16 bar		
Running time ¹⁾ :	8 s		
Stroke :	8 mm		
Valve	Δp_{max}	Δp_s	
VUE 015	10.0	16.0	
VUE 020	10.0	16.0	
VUE 025	10.0	12.0	
VUE 032	6.5	6.5	
VUE 040	4.0	4.0	
VUE 050	2.5	2.5	

For temperatures above 100 °C, accessories are required

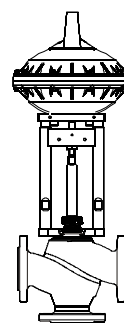

B10680

Drive	AVP 242 F021		
Perm. press. p_{stat}	≤ 16 bar		
Running time ¹⁾	8 s		
Stroke	20 mm		
Valve	Δp_{max}	Δp_s	
VUE 065	1.5	1.5	
VUE 080	1.0	1.0	

For temperatures above 130 °C, accessories are required

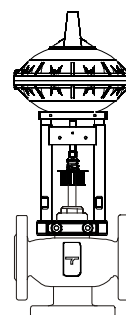

B10681

Combination of VUE, PN 16/10 with pneumatic drive AVP 243 / 244

Drive	AVP 243 F021		AVP 244 F021		
Perm. press. p_{stat}	≤ 16 bar		≤ 16 bar		
Running time ¹⁾	24 s		40 s		
Stroke	20 mm		20 mm		
Valve	Δp_{max}	Δp_s	Δp_{max}	Δp_s	
VUE 065	2.3	2.3	3.0	4.5	
VUE 080	1.5	1.5	3.0	3.0	

Drive	AVP 243 F031		AVP 244 F031		
Perm. press. p_{stat}	≤ 16 bar		≤ 16 bar		
Running time ¹⁾	24 s		40 s		
Stroke	40 mm		40 mm		
Valve	Δp_{max}	Δp_s	Δp_{max}	Δp_s	
VUE 100	1.0	1.0	2.0	2.0	
VUE 125	0.6	0.6	1.2	1.2	
VUE 150	0.4	0.4	1.0	1.0	

For temperatures above 130 °C, accessories are required

¹⁾ In relation to the Centair air rate (400 l_v/h) and to a pipe with length of 20 m and diameter of 4 mm

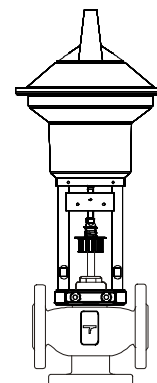

B10682

Valve: Variant F, for technical data and accessories see Valve Type Table
 Drive: Variant F, for technical data, accessories and installation position see section 71
 Example: VUE 065 F300 / AVP 243 F031
 Valve is closed when actuator is pressureless = factory setting
 Valve is open when actuator is pressureless = on request

Δp_{max} [bar]= Maximum permitted pressure difference across the valve at which the drive can still reliably open and close the valve, taking account of ΔP_v .
 Δp_s [bar]= Maximum permitted pressure difference across the valve in case of a fault (pipe break downstream of the valve) at which the drive can close the valve reliably with 'fast' performance of the stroke

Pressure-stroke characteristic (with valve fitted)
Characteristic is not adjustable:

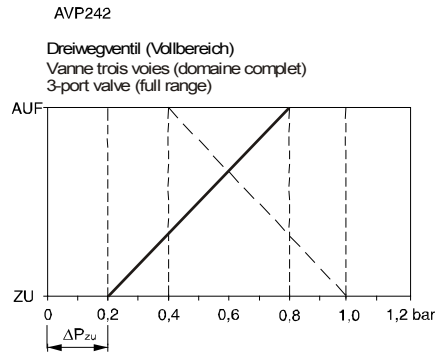
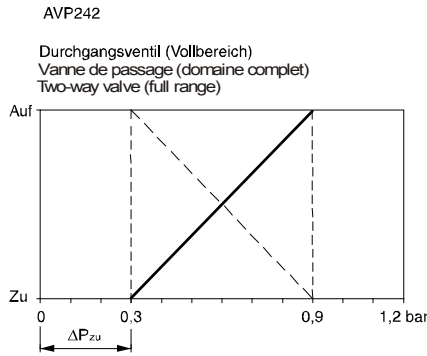

B10728

Characteristic is adjustable:

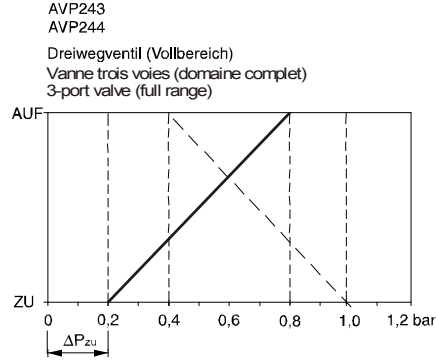
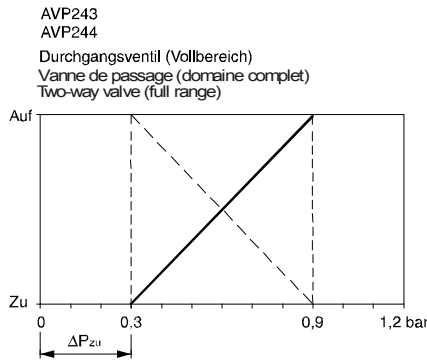

B10684

- = CLOSED without pressure (function E)
- = OPEN without pressure (function A)

Sequences with XSP31 are possible

Function

The valve can be moved to any intermediate position by means of a pneumatic drive. If the valve stem is extended, the control passage of the valve is closed. The valves must be used only with closure 'against the pressure'. The direction of flow marked on the valve must be observed. Closure with the pressure is not permissible with pneumatic drives, since it would cause pressure surges. The fluidic parameters comply with EN 60534.

Closing against the pressure

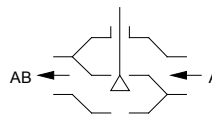

B01133a

Description

The key features of these control valves are their high reliability and precision, and they make a major contribution towards environment-friendly control. They meet demanding requirements including emergency positioning functions, coping with differential pressures, controlling the medium temperature and providing a shut-off function; all this is achieved with a low noise level.

An automatic and fixed connection is made between the valve stem and the drive shaft. The plug (which is made of brass) controls an equal-percentage flow in the control passage. The tightness of this valve is guaranteed by the seat which is machined in the body.

The stuffing box is maintenance-free; it consists of a brass body, 2 O-rings and a grease reserve. This is free of silicone grease and no silicone oil must be used for the stem. The grease reserve prevents any particles that might be present in the medium from reaching the upper O-ring.

Engineering and fitting notes

The drive is placed directly on top of the valve and is fixed with screws. The connection between the drive and the valve stem is made automatically. The closing point must be set as described in the installation instructions (MV 506012 AVP 242 or MV 506013 AVP 243/244).

Installation position

The final control element can be installed in any desired position, but an installed position facing downwards is not recommended. Condensate and water drips etc. must be prevented from penetrating into the drive. With a horizontal installed position and in relation to the valve stem, the permitted maximum drive (or other) weight is 25 kg unless a support is provided by the customer or others.

When fitting the drive onto the valve, you must make sure that the plug is not rotated on the seat (this would damage the sealing surface). If the valve is insulated, the insulation must only extend as far as the connecting clip of the drive.

Applications with steam

The valves may be used for low-pressure steam up to 115 °C with the same Δp_{\max} values, but we advise you only to use the valves for open-closed switching. For use as a control valve, you should make sure that the majority of the work is not done in the lower third of the valve stroke range. In this case, an extremely high flow speed would develop, severely reducing valve's lifetime.

Applications with water

To ensure that impurities in the water (such as welding beads or particles of rust, etc.) are retained and the stem seal is not damaged, it is advisable to install collective filters, e.g. for each storey or pipe run. Water quality requirements conform to VDI 2035. If an additional medium is used, the compatibility of the materials must be clarified with the manufacturer of the medium. The Material Table shown below can be used for this purpose. If glycol is used, we recommend that a concentration of between 20% and 55% should be selected.

The valves are not suitable for drinking water or in zones where there is a risk of explosions.

Other notes concerning hydraulics and noises in systems

The valves can be used in a low-noise environment. To avoid noises, the pressure differences Δp_{\max} listed below should not be exceeded.

Pressure difference Δp_v is the maximum pressure that may be present on the valve, regardless of the stroke position, so that the danger of cavitation and erosion is limited. These values are independent of the drive force. Cavitation accelerates wear on the plug and the seat in the valve, and causes noises. To prevent cavitation, differential pressure Δp_{\max} should not exceed value Δp_{krit} :

$$\Delta p_{\text{krit}} = (p_1 - p_v) \times 0,5$$

p_1 = upstream pressure in front of the valve (bar) p_v = steam/vapour pressure

Absolute pressure is used for the calculations.

The close/off pressure values which are also listed represent the maximum pressures at which the drive can still use its own force to move the valve. It should be pointed out here that if these pressures are used and the pressure difference Δp_{\max} is exceeded, the valve may sustain damage due to cavitation and erosion. In case of a spring return function, the stated Δp_s values also represent the permitted differential pressure up to which the drive guarantees closure of the valve in case of an incident. As this is an emergency function with 'fast' passage through the stroke (by means of the spring), this value may exceed Δp_{\max} .

Pressure loss table

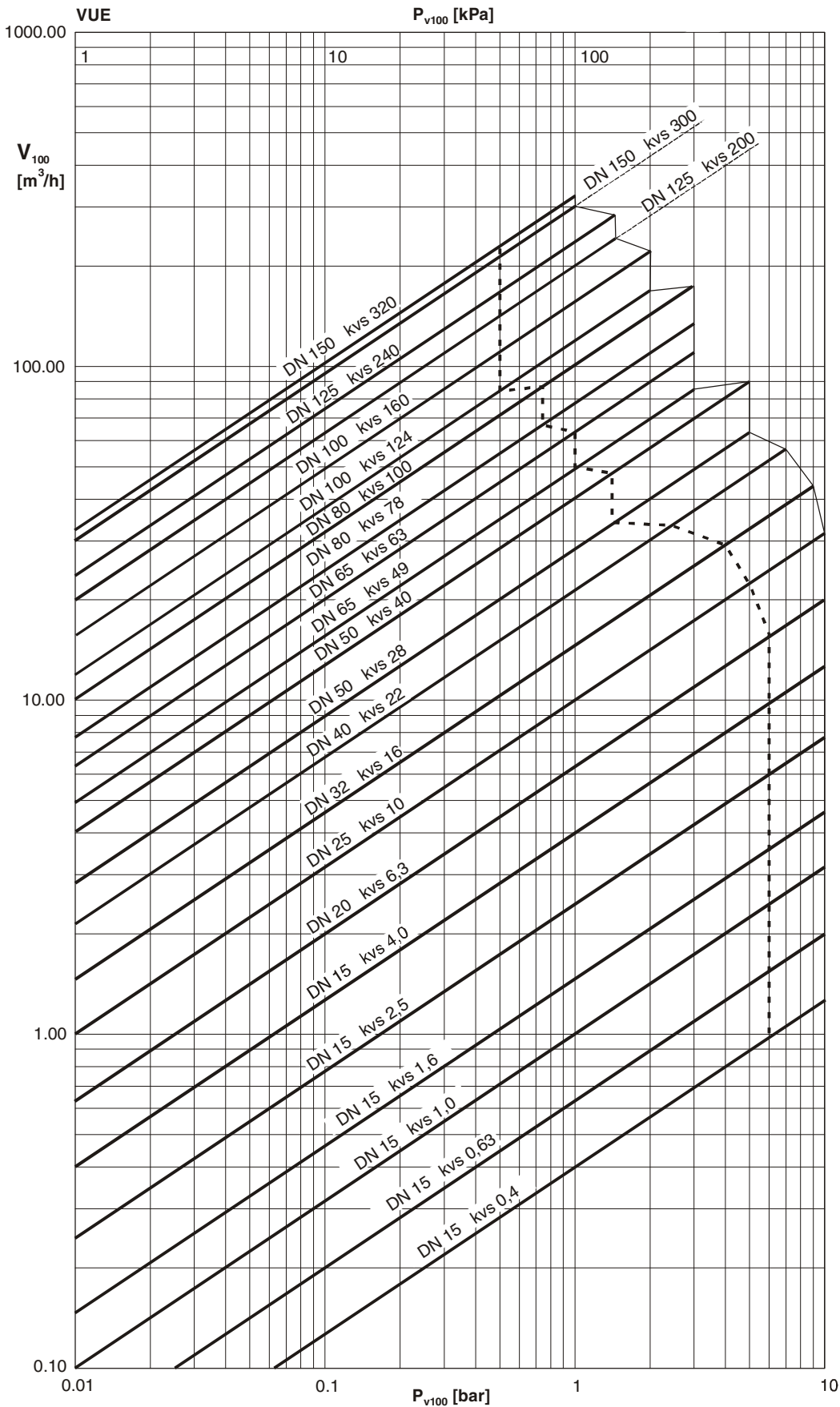

Type	Δp_v against the pressure
VUE 015	10
VUE 015	10
VUE 015	10
VUE 015	10
VUE 015	10
VUE 015	10
VUE 020	10
VUE 025	10
VUE 032	9
VUE 040	7
VUE 050	5
VUE 050	5
VUE 065	3
VUE 080	3
VUE 100	2
VUE 125	1,5
VUE 150	1,0

Additional technical data

- Pressure and temperature data
 Parameters related to flow mechanics
 Sauter slide rule for valve sizing
 Manual for slide rule
 Technical manual: 'Regulating Units'
 Parameters, installation notes, control, general

EN 764, EN 1333
 VDI/VDE 2173
 7 090011 001
 7 000129 001
 7 000477 001
 Valid EN, DIN, AD,
 TRD and UVV
 specifications /
 regulations
 97/23/EC
 Article 33
 Category I

- CE conformity, Pressure Equipment Directive (fluid group II)
 VUE 015 to VUE 050: no CE symbol
 VUE 065 to VUE 150 CE symbol

Additional information

Valve body made of grey cast iron to EN 1563, code EN-GJL-250, material number EN-JL 1040 with smooth drilled flanges to EN 1092-2, form B, sealing strip. Valve body to RAL 9005, dark black. Recommendation for welding-neck flange as per EN 1092-2. Overall valve length to EN 558-1, basic series 1. Flat seal on valve body made of asbestos-free material.

DIN material numbers

	DIN material number	DIN designation
Valve body	EN-JL 1040	EN-GJL-250 (GG25)
Valve seat	EN-JL 1040	EN-GJL-250
Stem	1.4305	X 8 Cr Ni S 18-9
Plug	CW 617 W	CuZn40Pb2
Plug seal	PTFE	
Stuffing box	CW 617 W	CuZn40Pb2
Valve body	EN-JL 1040	EN-GJL-250 (GG25)

Detailed information on pressure difference definitions

Δp_v :

Maximum permissible pressure difference across the valve in any stroke position, limited by the noise level and erosion.

The valve as a traversed element is defined by this parameter specifically in its hydraulic behaviour. By monitoring cavitation, erosion and the noise thus produced, improvements can be achieved in both life expectancy and durability.

Δp_{max} :

Maximum permissible pressure difference across the valve at which the drive can firmly open and close the valve.

Static pressure and fluidic influences are taken into account. This value helps to maintain smooth stroke action and valve sealing. In doing so, the valve's Δp_v value is not exceeded.

Δp_s :

Maximum permissible pressure difference across the valve in the event of a malfunction (e.g. power failure) at which the drive can firmly close the valve and, if necessary, hold the full operating pressure against atmospheric pressure. Since this is a safety function with 'fast' stroke, Δp_s can be larger than Δp_{max} or, respectively, Δp_v . The resultant fluidic disturbances are soon overcome and play a minor role here.

On the three-way valves, the values apply only for the control passage.

Δp_{stat} :

Line pressure across the valve. This corresponds largely to the dead pressure when the pump is switched off, e.g. due to the level of liquid in the plant, an increase in pressure via the pressure store, steam pressure etc.

On valves that close with the pressure, the static pressure plus the pump pressure should be used.

Dimension drawings

DN 15...50

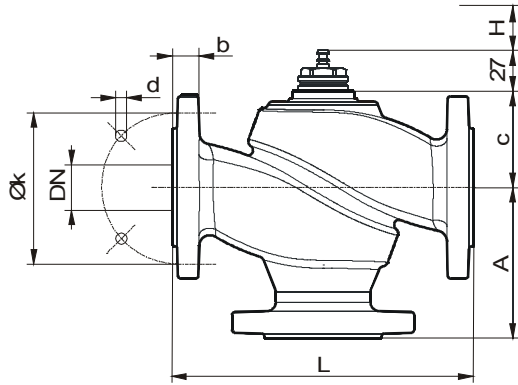

VUE, BUE	DN	A	c	L	H	k	d	b
015	15	70	41,5	130	8	65	14 x 4	14
020	20	75	48	150	8	75	14 x 4	16
025	25	80	54,5	160	8	85	14 x 4	16
032	32	95	60,5	180	8	100	19 x 4	18
040	40	100	70,5	200	8	110	19 x 4	18
050	50	115	71	230	8	125	19 x 4	20

M10437c

DN65...150

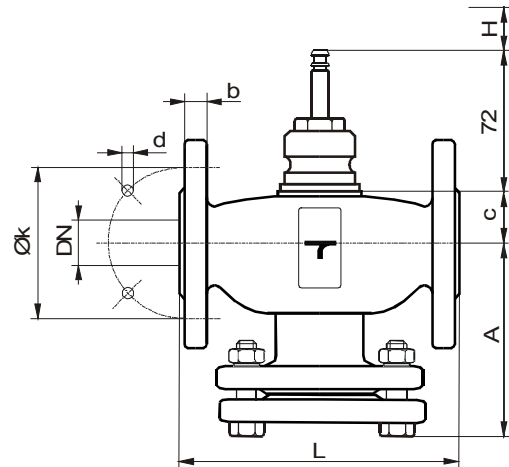

VUE	DN	A	c	L	H	k	d	b
065	65	173	62	290	20	145	19 x 4	20
080	80	185	62	310	20	160	19 x 8	22
100	100	205	93	350	40	180	19 x 8	24
125	125	232	105,5	400	40	210	19 x 8	26
150	150	275	120	480	40	240	23 x 8	26

M10439b

AVP 242 F001

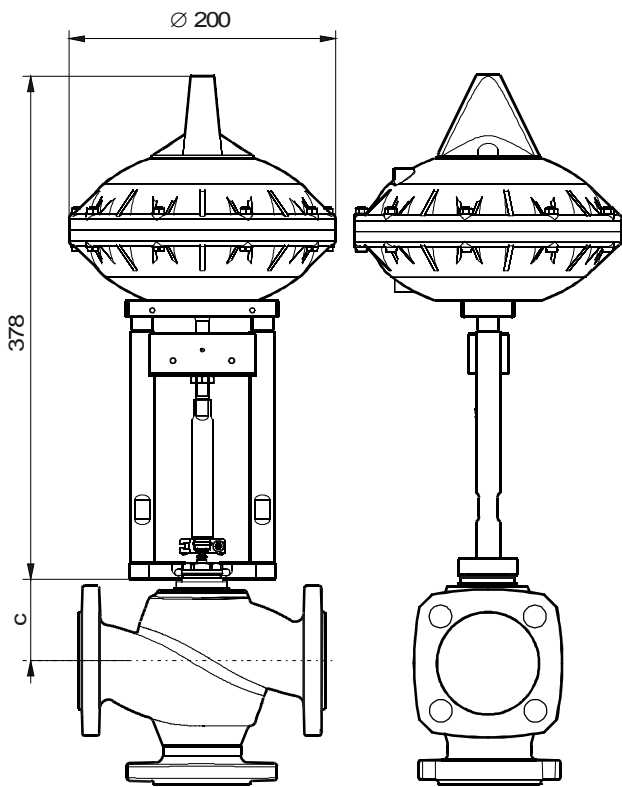

AVP 242 F021

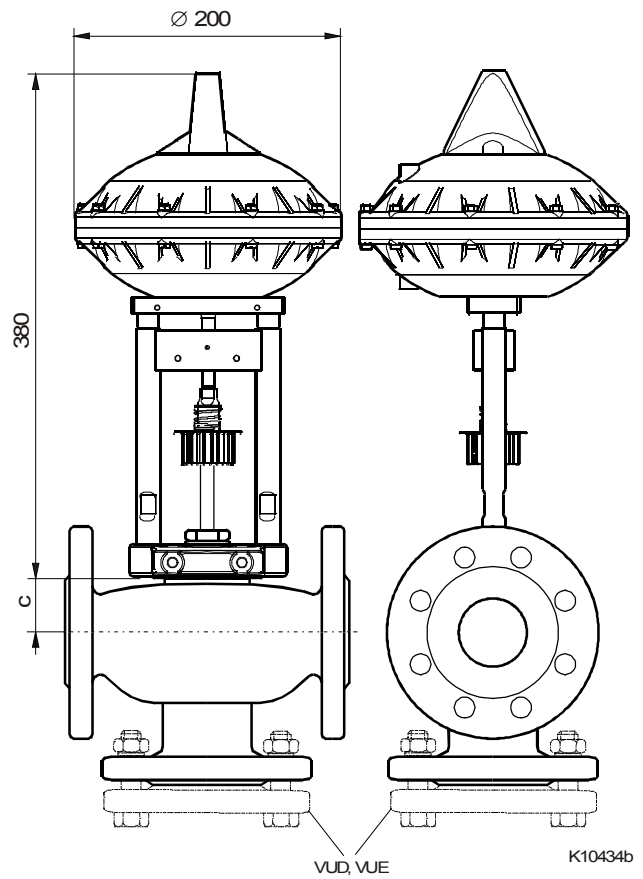

AVP 243/244

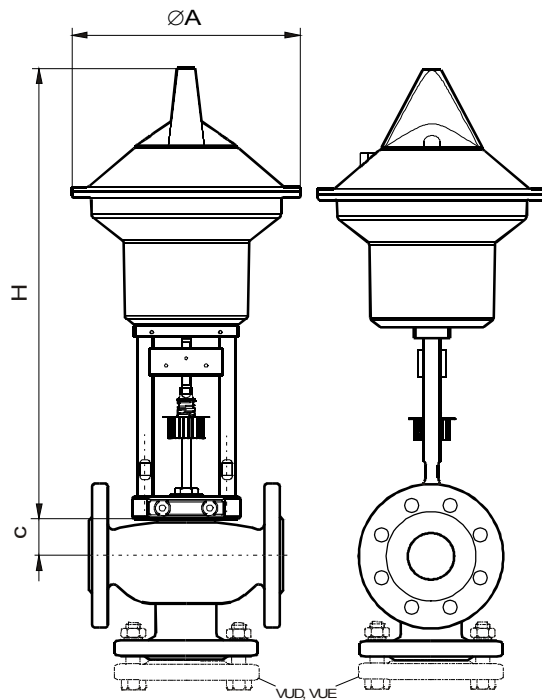

AVP ...	A	H
243 F021	250	497
243 F031	250	517
244 F021	335	536
244 F031	335	556

K10435a

Accessories

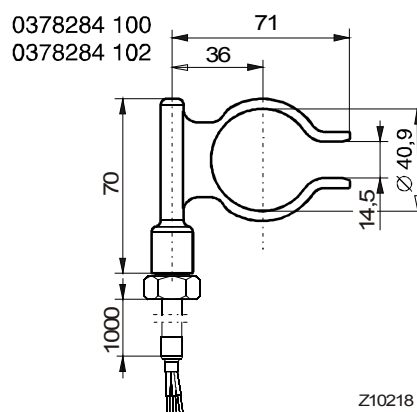
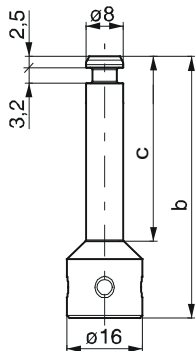
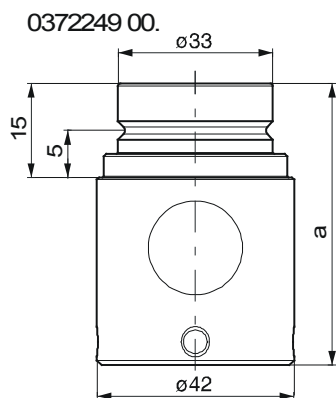

Z10218

	a [mm]	b [mm]	c [mm]
0372249 001	60	55,8	40
0372249 002	80	75,8	60

Z10220