

Jola - Continuous liquid level measurement with TSQ 4-20/... and TSK 4-20/... liquid level indicators

for remote transmission of liquid levels using the float method

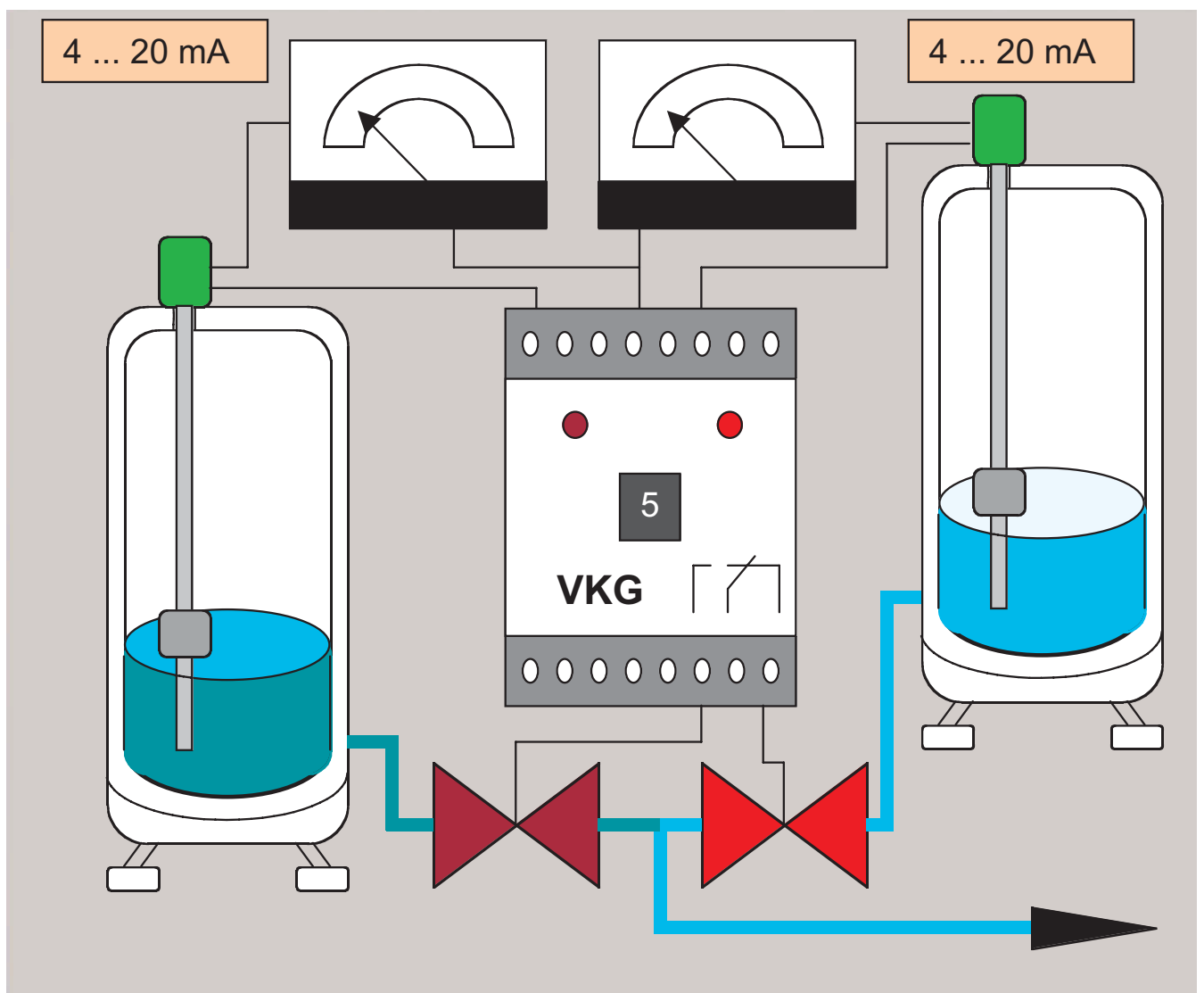

Jola Spezialschalter K. Mattil & Co. KG

P.O.B. 11 49 · D-67460 Lambrecht (Pfalz) · Phone: +49 63 25/1 88-01 · Fax: +49 63 25/63 96
E-Mail: kontakt@jola-info.de · Website: www.jola-info.de

Contents

Pages

TSQ 4-20/... liquid level indicators consisting of

- sensor:

Switchable resistances activated by float via reed contacts.

- transmitter:

A 2-wire module in the terminal box of the liquid level indicator converts the resistance values into a load-independent current signal 4 ... 20 mA.

5-1-1 to 5-1-15

Questionnaire for customized design

5-1-16

TSK 4-20/... liquid level indicators consisting of

- sensor:

Potentiometer adjusted by float via a transmission chain.

- transmitter:

A 2-wire module in the terminal box of the liquid level indicator converts the potentiometer position into a load-independent current signal 4 ... 20 mA

5-1-17 to 5-1-21

SKG 420 switching unit for signalling 1 limit level, with integrated liquid level indicator feed

5-1-22 and 5-1-23

ZKG 420 switching unit for level regulation between 2 limit levels, with integrated liquid level indicator feed

5-1-24 and 5-1-25

VKG 420-1020 switching unit for comparison of 2 signals, with integrated liquid level indicator feed

5-1-26 to 5-1-28

Indicating instrument

5-1-29

Connecting diagram

5-1-30

Jola - TSQ 4-20/... liquid level indicator

Consisting of

- sensor:

Switchable resistances activated by float via reed contacts.

- transmitter:

A 2-wire module in the terminal box of the liquid level indicator converts the resistance values into a load-independent current signal 4 ... 20 mA.

Working principle

A float with built-in permanent magnet moves up and down with the liquid level on the probe tube of the TSQ 4-20/... liquid level indicator.

Inside the probe tube, there is a chain made up of reed contacts and series-connected resistors. The magnet in the float switches the reed contact(s) which are at the same position as the float. This results in quasi-continuous height-proportional resistance measurement.

The change in resistance resulting from the upward and downward motion of the float is recorded via a current loop transmitter in the terminal box of the TSQ 4-20/... liquid level indicator and converted into a load-independent current 4 ... 20 mA.

Area of application

The TSQ 4-20/... liquid level indicator is designed for use in low-viscosity liquids or liquids with only low solid content in open or closed tanks. It is not suitable for use in liquids that are prone to deposit formation, adhesion or crystallisation which might hinder the movement of the float on the probe tube. It is also not suitable for use in liquids with **permanently** moving surface and/or on vibrating machines.

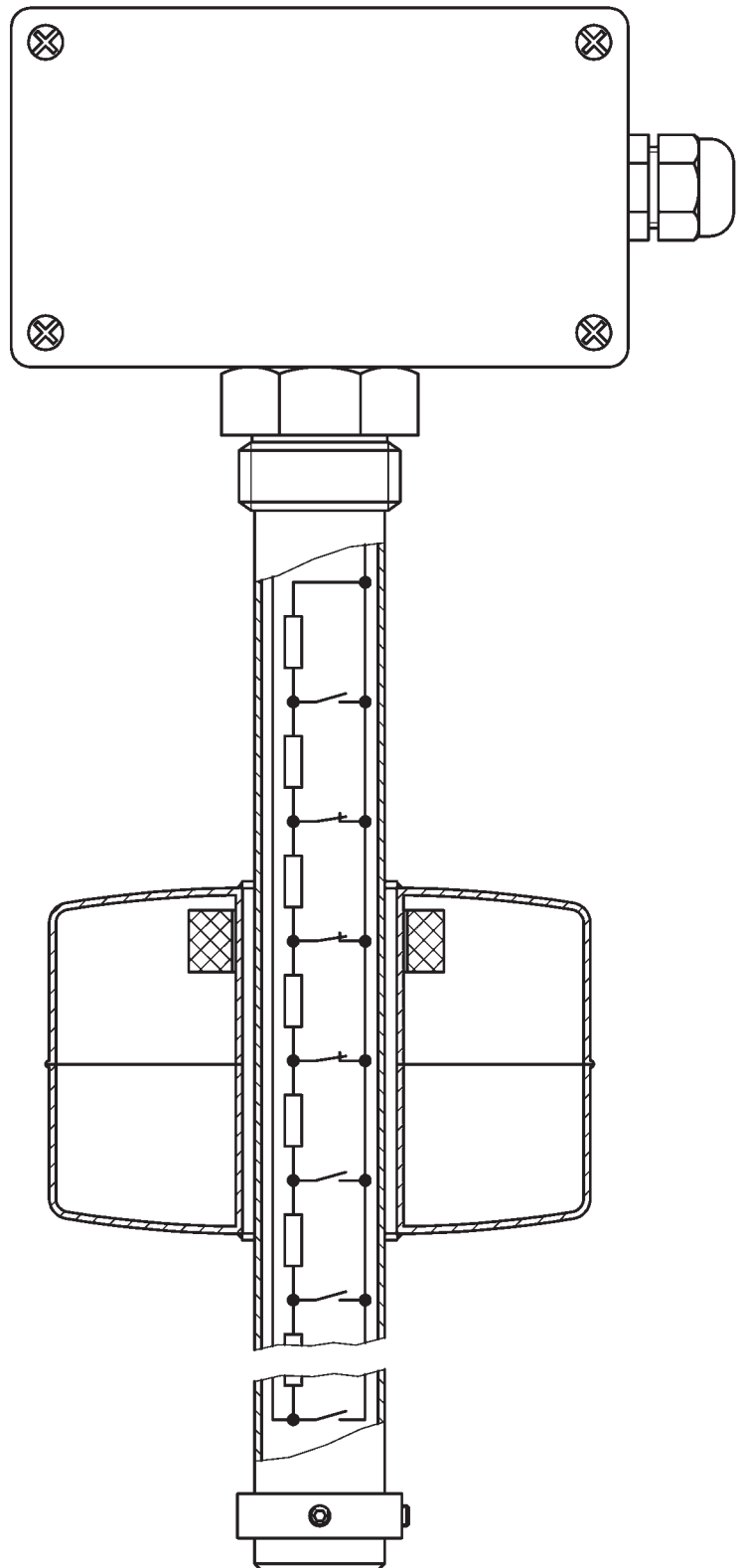

Types	Distance between 2 reed contacts						Max. length of probe tube
	3.75	7.5	15	22.5	30	37.5	
TSQ 4-20/ED/P/...	—	●	—	—	—	—	1,500 mm
TSQ 4-20/ED/PK/...	—	●	—	—	—	—	1,500 mm
TSQ 4-20/ED/E 1/...	—	●	—	—	—	—	1,500 mm
TSQ 4-20/ED/E 2/...	—	●	—	—	—	—	1,500 mm
TSQ 4-20/ED/E 3/...	—	●	—	—	—	—	1,500 mm
TSQ 4-20/ED/E 5/...	—	●	—	—	—	—	1,500 mm
TSQ 4-20/EW/E 5/...	●	●	—	—	—	—	1,500 mm
TSQ 4-20/EW/E 9/...	—	—	●	●	●	●	4,000 mm
TSQ 4-20/P/P/...	—	●	—	—	—	—	750 mm
TSQ 4-20/P/PG/...	—	●	—	—	—	—	1,500 mm
TSQ 4-20/PVDF/D/...	—	●	—	—	—	—	750 mm
TSQ 4-20/PVDF/W/...	—	●	—	—	—	—	1,500 mm

	Probe tube		Float		Page
	Material	Ext. Ø	Material	Dimensions	
	stainless steel 316 Ti	12 mm	PP	53 mm Ø x 50 mm	5-1-5
	stainless steel 316 Ti	12 mm	PP	29 mm Ø x 50 mm	5-1-5
	stainless steel 316 Ti	12 mm	stainless steel 316 Ti	73 mm Ø (ball)	5-1-7
	stainless steel 316 Ti	12 mm	stainless steel 316 Ti	44.5 mm Ø x 52 mm	5-1-7
	stainless steel 316 Ti	12 mm	stainless steel 316 Ti	52 mm Ø x 85 mm	5-1-9
	stainless steel 316 Ti	12 mm	stainless steel 316 Ti	97 mm Ø (ball)	5-1-9
	stainless steel 316 Ti	20 mm	stainless steel 316 Ti	97 mm Ø (ball)	5-1-11
	stainless steel 316 Ti	20 mm	stainless steel 316 Ti	97 mm Ø x 100 mm	5-1-11
	PP	14 mm	PP	53 mm Ø x 50 mm	5-1-13
	PP	16 mm	PP	90 mm Ø x 60 mm	5-1-13
	PVDF	14 mm	PVDF	53 mm Ø x 50 mm	5-1-15
	PVDF	16 mm	PVDF	90 mm Ø x 60 mm	5-1-15

Technical data	TSQ 4-20/ED/P/7.5	TSQ 4-20/ED/PK/7.5
Sensor		
Probe tube material	stainless steel 316 Ti	
Probe tube diameter	12 mm	
Probe tube length	according to customer specification taking into account the max. length of the probe tube	
Max. probe tube length	1,500 mm	400 mm
Screw-in nipple	G½, on request G1, G1½ or G2;	G1, on request G½, G1½ or G2;
	on request with reducing nipple made of cast iron R1½ or R2 conical or cast steel G2	
Float	PP, 53 mm Ø x 50 mm high (mounting through a R2 or G2 socket possible)	PP, 29 mm Ø x 50 mm high (mounting through a G1 socket possible)
Float suitable for use in liquids with a specific gravity	≥ 0.8 g/cm ³	≥ 0.85 g/cm ³
Terminal box	PP, A 307, 120 x 80 x 55 mm, protection class IP 65	
Mounting orientation	vertical	
Temperature application range	from - 20°C to + 80°C	
Pressure resistance at + 20°C	max. 2 bar	
Measuring principle	the magnet of the float activates switchable series-connected resistances via reed contacts. This provides a quasi-continuous height-proportional measuring signal	
Measuring precision	distance between 2 reed contacts: 7.5 mm	
Transmitter		
Measuring electronics	2 wires (independent of polarity)	
Setting possibility	0 % value not adjustable, 100 % value adjustable via a potentiometer	
Power supply	DC 15 - 30 V (independent of polarity)	
Measuring signal	4 ... 20 mA	
Admiss. load in the current loop	max. 200 ohm at 15 V; max. 900 ohm at 30 V	
Connecting terminals	for max. 2.5 mm ² solid cable or max. 1.5 mm ² flexible cable	
EMC	for interference emission in accordance with the appliance-specific requirements for households, business and commerce as well as small companies, and for interference immunity in accordance with the appliance-specific requirements for industrial companies.	



TSQ 4-20/ED/P/7.5

TSQ 4-20/ED/PK/7.5
with G¹/₂
screw-in nipple

Float for
TSQ 4-20/ED/P/7.5

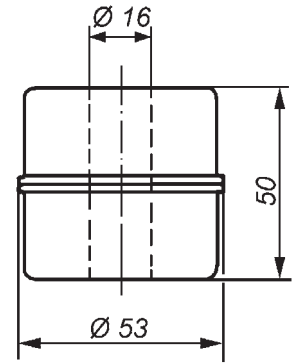

Float for
TSQ 4-20/ED/PK/7.5

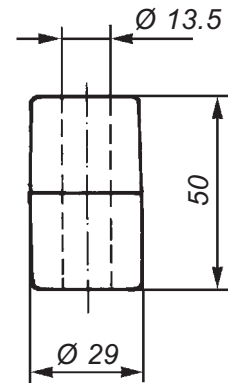

Square flange

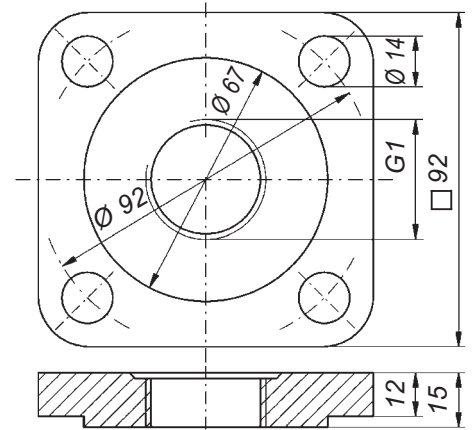

Counter flange

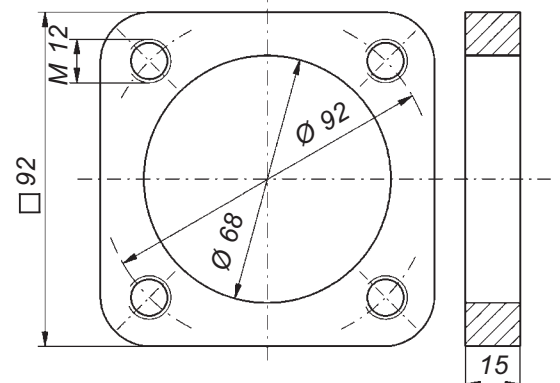

Mounting accessories

Square flange made of stainless steel 316 Ti, steel, PP or PVDF for liquid level indicator with G¹/₂ screw-in nipple. Counter flange on request.

Technical data	TSQ 4-20/ED/E 1/7.5	TSQ 4-20/ED/E 2/7.5
Sensor		
Probe tube material	stainless steel 316 Ti	
Probe tube diameter	12 mm	
Probe tube length	according to customer specification taking into account the max. length of the probe tube	
Max. probe tube length	1,500 mm	
Screw-in nipple	G $\frac{1}{2}$, on request G1, G1 $\frac{1}{2}$ or G2; on request with reducing nipple made of cast iron R1 $\frac{1}{2}$ or R2 conical or cast steel G2	
Float	stainless steel 316 Ti, 73 mm \varnothing (ball)	stainless steel 316 Ti, 44.5 mm \varnothing x 52 mm high (mounting through a R1 $\frac{1}{2}$ or G1 $\frac{1}{2}$ socket possible)
Float suitable for use in liquids with a specific gravity	$\geq 0.7 \text{ g/cm}^3$	$\geq 0.95 \text{ g/cm}^3$
Terminal box	PP, A 307, 120 x 80 x 55 mm, protection class IP 65	
Mounting orientation	vertical	
Temperature application range	from - 20°C to + 80°C	
Pressure resistance at + 20°C	max. 12 bar	
Measuring principle	the magnet of the float activates switchable series-connected resistances via reed contacts. This provides a quasi-continuous height-proportional measuring signal	
Measuring precision	distance between 2 reed contacts: 7.5 mm	
Transmitter		
Measuring electronics	2 wires (independent of polarity)	
Setting possibility	0 % value not adjustable, 100 % value adjustable via a potentiometer	
Power supply	DC 15 - 30 V (independent of polarity)	
Measuring signal	4 ... 20 mA	
Admiss. load in the current loop	max. 200 ohm at 15 V; max. 900 ohm at 30 V	
Connecting terminals	for max. 2.5 mm ² solid cable or max. 1.5 mm ² flexible cable	
EMC	for interference emission in accordance with the appliance-specific requirements for households, business and commerce as well as small companies, and for interference immunity in accordance with the appliance-specific requirements for industrial companies.	

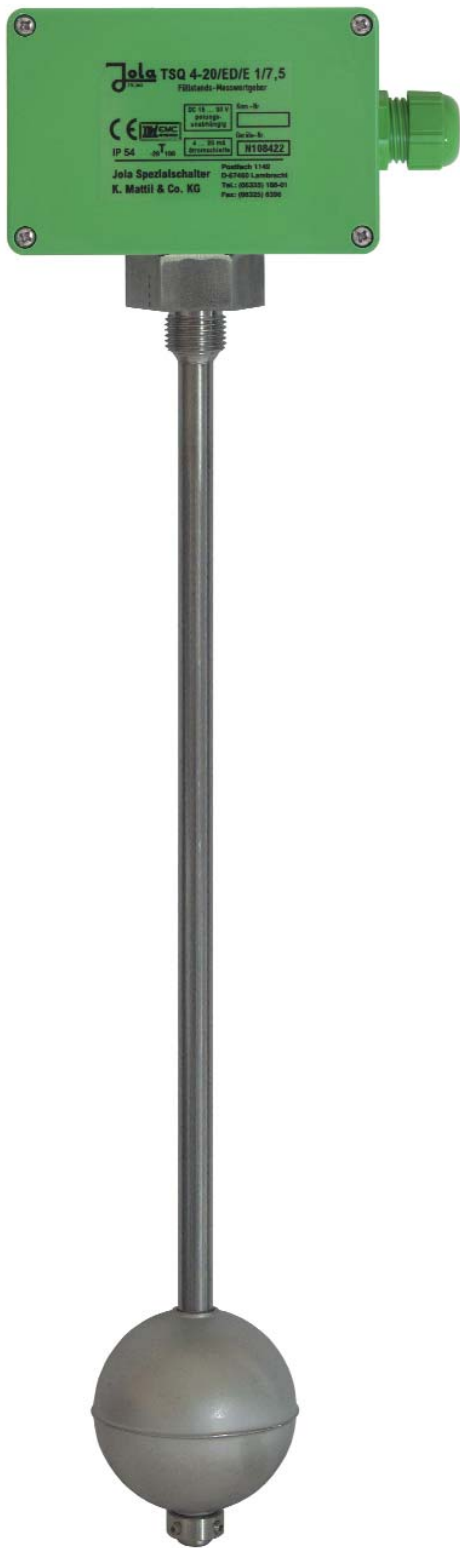

TSQ 4-20/ED/E 1/7.5

Float for
TSQ 4-20/ED/E 1/7.5

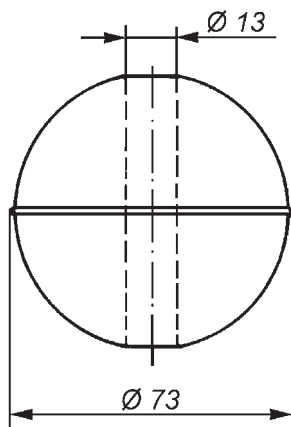

Float for
TSQ 4-20/ED/E 2/7.5

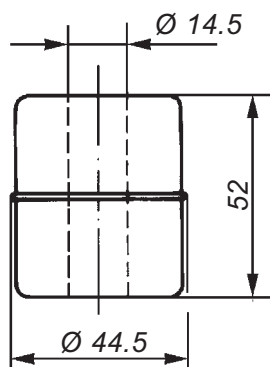

TSQ 4-20/ED/E 2/7.5

Mounting accessories

Square flange made of stainless steel 316 Ti, steel, PP or PVDF for liquid level indicator with G1 screw-in nipple. Counter flange on request.

Dimensions see page 5-1-6.

Technical data	TSQ 4-20/ED/E 3/7.5	TSQ 4-20/ED/E 5/7.5
Sensor		
Probe tube material	stainless steel 316 Ti	
Probe tube diameter	12 mm	
Probe tube length	according to customer specification taking into account the max. length of the probe tube	
Max. probe tube length	1,500 mm	
Screw-in nipple	G $\frac{1}{2}$, on request G1, G1 $\frac{1}{2}$ or G2; on request with reducing nipple made of cast iron R1 $\frac{1}{2}$ or R2 conical or cast steel G2	
Float	stainless steel 316 Ti, 52 mm Ø x 85 mm high (mounting through a R2 or G2 socket possible)	stainless steel 316 Ti, 97 mm Ø (ball)
Float suitable for use in liquids with a specific gravity	≥ 0.7 g/cm ³	
Terminal box	PP, A 307, 120 x 80 x 55 mm, protection class IP 65	
Mounting orientation	vertical	
Temperature application range	from - 20°C to + 80°C	
Pressure resistance at + 20°C	max. 12 bar	
Measuring principle	the magnet of the float activates switchable series-connected resistances via reed contacts. This provides a quasi-continuous height-proportional measuring signal	
Measuring precision	distance between 2 reed contacts: 7.5 mm	
Transmitter		
Measuring electronics	2 wires (independent of polarity)	
Setting possibility	0 % value not adjustable, 100 % value adjustable via a potentiometer	
Power supply	DC 15 - 30 V (independent of polarity)	
Measuring signal	4 ... 20 mA	
Admiss. load in the current loop	max. 200 ohm at 15 V; max. 900 ohm at 30 V	
Connecting terminals	for max. 2.5 mm ² solid cable or max. 1.5 mm ² flexible cable	
EMC	for interference emission in accordance with the appliance-specific requirements for households, business and commerce as well as small companies, and for interference immunity in accordance with the appliance-specific requirements for industrial companies.	



TSQ 4-20/ED/E 3/7.5

**Float for
TSQ 4-20/ED/E 3/7.5**

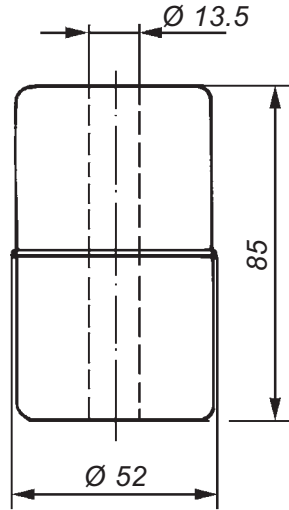

**Float for
TSQ 4-20/ED/E 5/7.5**

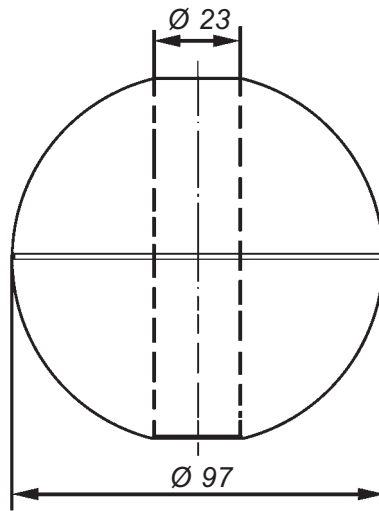

TSQ 4-20/ED/E 5/7.5

Technical data	TSQ 4-20/EW/E 5/...	TSQ 4-20/EW/E 9/...
Sensor		
Probe tube material	stainless steel 316 Ti	
Probe tube diameter	20 mm	
Probe tube length	according to customer specification taking into account the probe tube length	
Max. probe tube length	1,500 mm	4,000 mm
Screw-in nipple	G1, on request G1½ or G2; on request with reducing nipple made of cast iron R1½ or R2 conical or cast steel G2	
Float	stainless steel 316 Ti, 97 Ø mm (ball)	stainless steel 316 Ti, 97 mm Ø x 100 mm high
Float suitable for use in liquids with a specific gravity	≥ 0.7 g/cm ³	≥ 0.8 g/cm ³
Terminal box	PP, A 307, 120 x 80 x 55 mm, protection class IP 65	
Mounting orientation	vertical	
Temperature application range	from - 20°C to + 80°C	
Pressure resistance at + 20°C	max. 12 bar	max. 8 bar
Measuring principle	the magnet of the float activates switchable series-connected resistances via reed contacts. This provides a quasi-continuous height-proportional measuring signal	
Measuring precision	to be specified: ... mm distance between 2 reed contacts (additional type designation):	
	3.75 7.5	15 22.5 30 37.5
Transmitter		
Measuring electronics	2 wires (independent of polarity)	
Setting possibility	0 % value not adjustable, 100 % value adjustable via a potentiometer	
Power supply	DC 15 - 30 V (independent of polarity)	
Measuring signal	4 ... 20 mA	
Admiss. load in the current loop	max. 200 ohm at 15 V; max. 900 ohm at 30 V	
Connecting terminals	for max. 2.5 mm ² solid cable or max. 1.5 mm ² flexible cable	
EMC	for interference emission in accordance with the appliance-specific requirements for households, business and commerce as well as small companies, and for interference immunity in accordance with the appliance-specific requirements for industrial companies.	



TSQ 4-20/EW/E 5/7.5

**Float for
TSQ 4-20/EW/E 5/...**

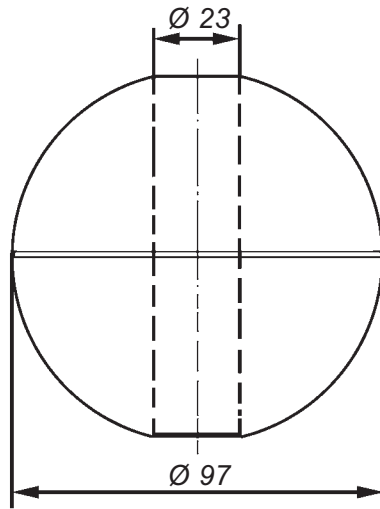

**Float for
TSQ 4-20/EW/E 9/...**

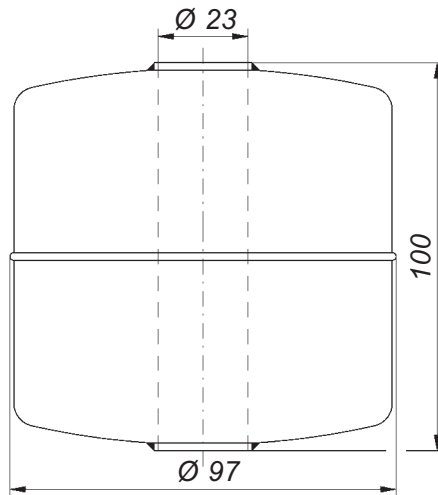

TSQ 4-20/EW/E 9/15

Technical data	TSQ 4-20/P/P/7.5	TSQ 4-20/P/PG/7.5
Sensor		
Probe tube material		PP
Probe tube diameter	14 mm	16 mm
Probe tube length	according to customer specification taking into account the max. temperature in the tank and the max. length of the probe tube (see below)	
Max. probe tube length	750 mm	1,500 mm
Screw-in nipple	G1, on request G2; on request with G2 reducing nipple made of ABS	
Float	PP, 53 mm Ø x 50 mm high (mounting through a G2 socket possible)	PP, 90 mm Ø x 60 mm high
Float suitable for use in liquids with a specific gravity	≥ 0.8 g/cm ³	
Terminal box	PP, A 307, 120 x 80 x 55 mm, protection class IP 65	
Mounting orientation	vertical	
Temperature application range taking into account the probe tube length:		
- up to max. 1,500 mm	—	from 0°C to + 40°C
- up to max. 1,000 mm	—	from 0°C to + 50°C
- up to max. 750 mm	from 0°C to + 60°C	from 0°C to + 60°C
- up to max. 500 mm	from 0°C to + 75°C	from 0°C to + 75°C
- up to max. 400 mm	from 0°C to + 80°C	from 0°C to + 80°C
Pressure resistance at + 20°C	max. 2 bar	
Measuring principle	the magnet of the float activates switchable series-connected resistances via reed contacts. This provides a quasi-continuous height-proportional measuring signal	
Measuring precision	distance between 2 reed contacts: 7.5 mm	
Transmitter		
Measuring electronics	2 wires (independent of polarity)	
Setting possibility	0 % value not adjustable, 100 % value adjustable via a potentiometer	
Power supply	DC 15 - 30 V (independent of polarity)	
Measuring signal	4 ... 20 mA	
Admiss. load in the current loop	max. 200 ohm at 15 V; max. 900 ohm at 30 V	
Connecting terminals	for max. 2.5 mm ² solid cable or max. 1.5 mm ² flexible cable	
EMC	for interference emission in accordance with the appliance-specific requirements for households, business and commerce as well as small companies, and for interference immunity in accordance with the appliance-specific requirements for industrial companies.	

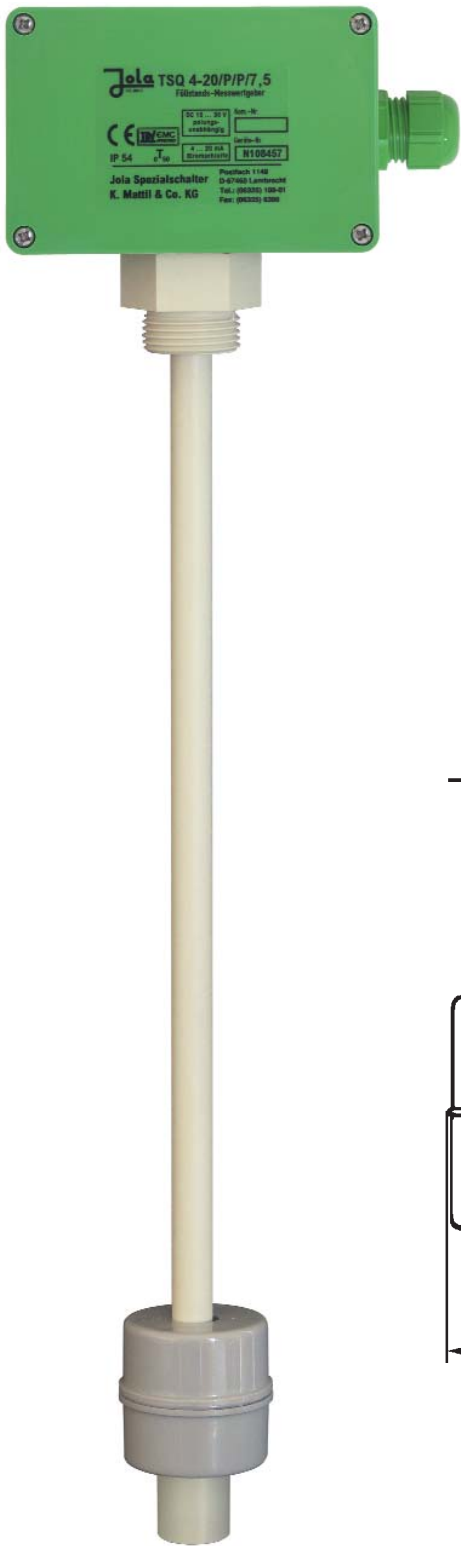

TSQ 4-20/P/P/7.5

**Float for
TSQ 4-20/P/P/7.5**

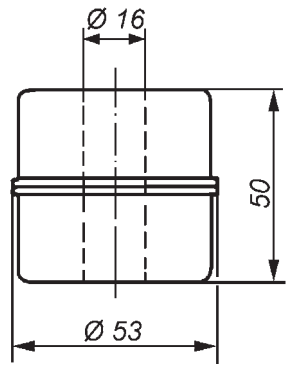

**Float for
TSQ 4-20/P/PG/7.5**

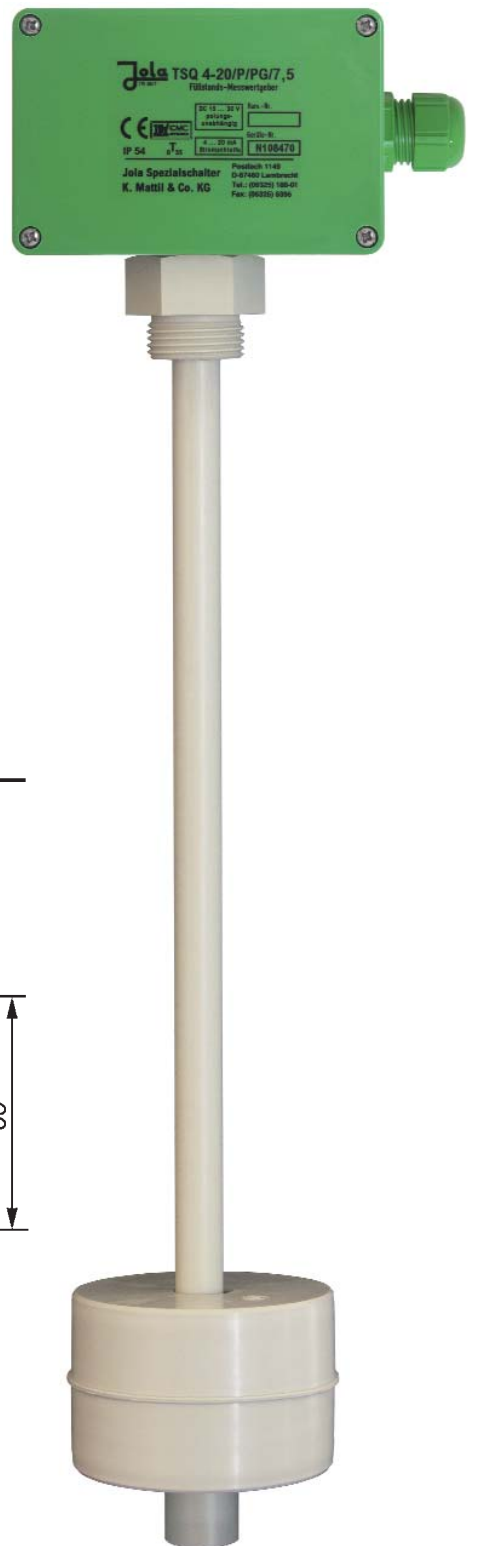
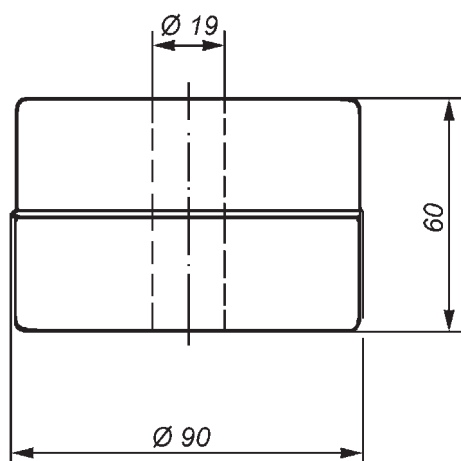

TSQ 4-20/P/PG/7.5

Mounting accessories

Square flange made of PP for liquid level indicator with G1 screw-in nipple.
Counter flange on request.

Dimensions see page 5-1-6.

Technical data	TSQ 4-20/PVDF/D/7.5	TSQ 4-20/PVDF/W/7.5
Sensor		
Probe tube material	PVDF	
Probe tube diameter	14 mm	16 mm
Probe tube length	according to customer specification taking into account the max. temperature in the tank and the max. length of the probe tube (see below)	
Max. probe tube length	750 mm	1,500 mm
Screw-in nipple	G1, on request G2	
Float	PVDF, 53 mm Ø x 50 mm high (mounting through a G2 socket possible)	PVDF, 90 mm Ø x 60 mm high
Float suitable for use in liquids with a specific gravity	$\geq 1 \text{ g/cm}^3$	
Terminal box	PP, A 307, 120 x 80 x 55 mm, protection class IP 65	
Mounting orientation	vertical	
Temperature application range taking into account the probe tube length:		
- up to max. 1,500 mm	—	from 0°C to + 45°C
- up to max. 1,000 mm	—	from 0°C to + 55°C
- up to max. 750 mm	from 0°C to + 70°C	from 0°C to + 70°C
- up to max. 500 mm	from 0°C to + 80°C	from 0°C to + 80°C
Pressure resistance at + 20°C	max. 2 bar	
Measuring principle	the magnet of the float activates switchable series-connected resistances via reed contacts. This provides a quasi-continuous height-proportional measuring signal	
Measuring precision	distance between 2 reed contacts: 7.5 mm	
Transmitter		
Measuring electronics	2 wires (independent of polarity)	
Setting possibility	0 % value not adjustable, 100 % value adjustable via a potentiometer	
Power supply	DC 15 - 30 V (independent of polarity)	
Measuring signal	4 ... 20 mA	
Admiss. load in the current loop	max. 200 ohm at 15 V; max. 900 ohm at 30 V	
Connecting terminals	for max. 2.5 mm ² solid cable or max. 1.5 mm ² flexible cable	
EMC	for interference emission in accordance with the appliance-specific requirements for households, business and commerce as well as small companies, and for interference immunity in accordance with the appliance-specific requirements for industrial companies.	

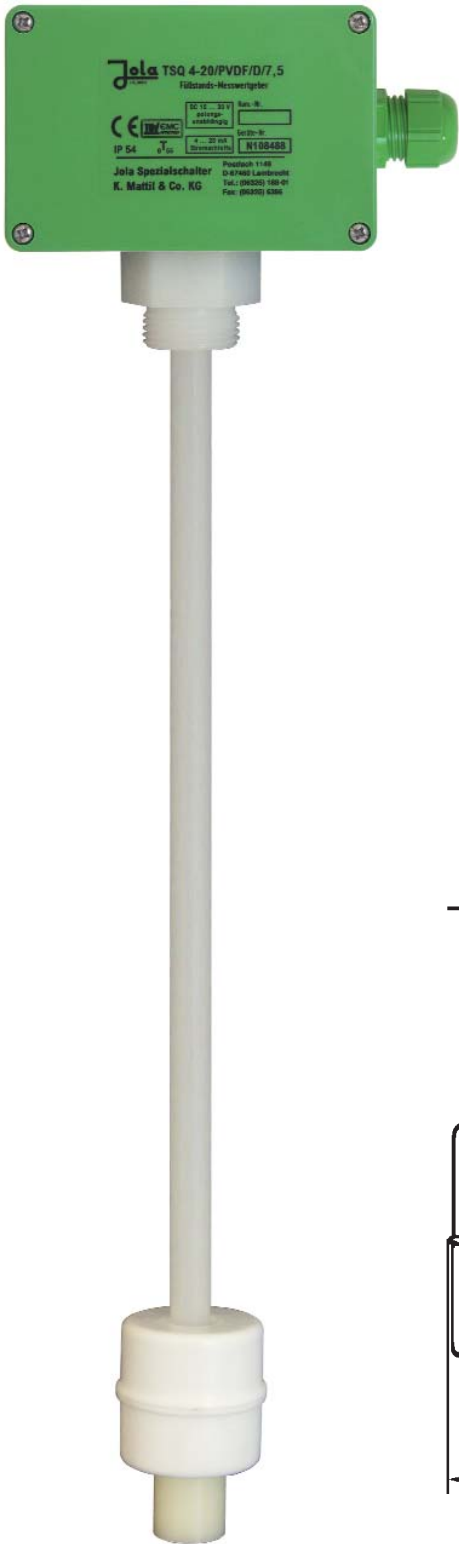

TSQ 4-20/PVDF/D/7.5

Float for
TSQ 4-20/PVDF/D/7.5

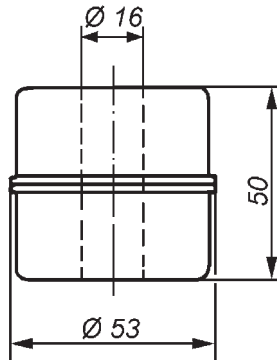

Float for
TSQ 4-20/PVDF/W/7.5

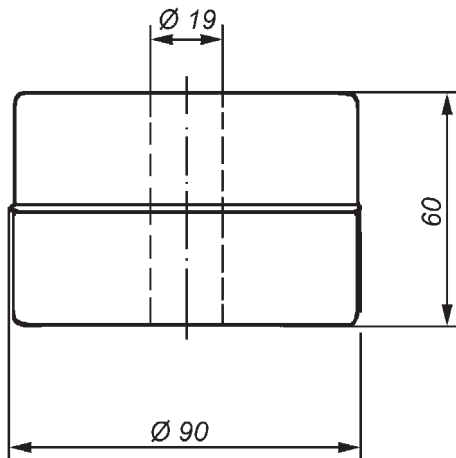

TSQ 4-20/PVDF/W/7.5

Mounting accessories

Square flange made of PVDF for liquid level indicator with G1 screw-in nipple.
Counter flange on request.

Dimensions see page 5-1-6.

**Questionnaire for the customised design of the liquid level indicator TSQ 4-20/...
(please cross as applicable)**

Signal evaluation

Position of terminal box:

Desired probe tube length (dimension G):

* = Please specify dimension D if explicitly desired, otherwise approx. 15 - 20 mm

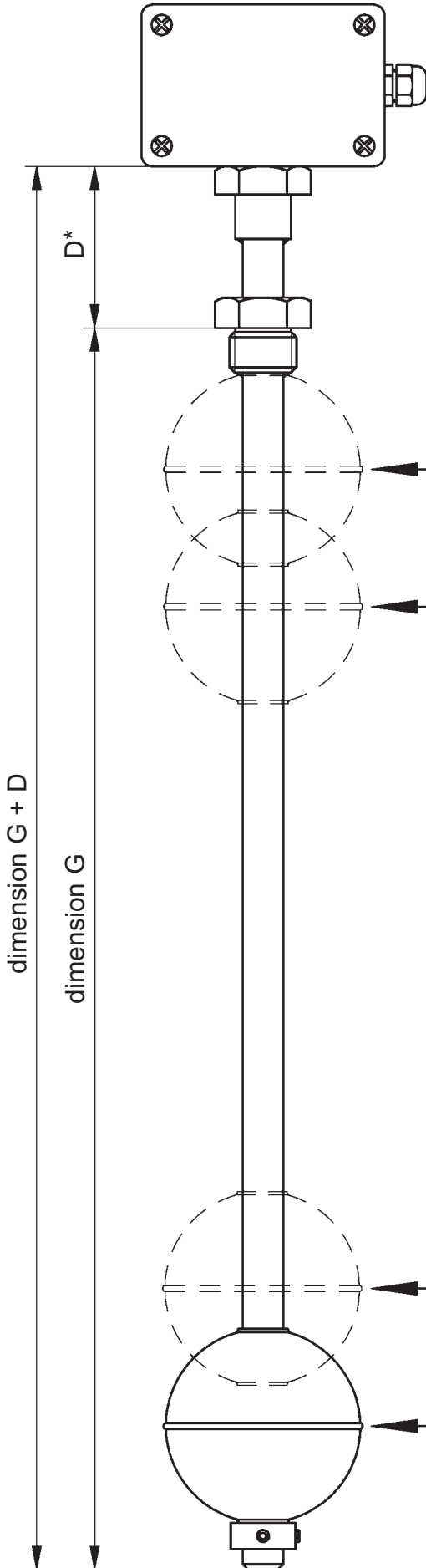

100 % set to maximum filling level that can be evaluated

or

100 % set to desired filling level; the 100 % value is retained if this level is exceeded

or

100 % set to desired filling level; if exceeded, the value jumps to a higher value, e.g. 120 %, and remains there

or

100 % set to maximum filling level that can be evaluated; adjusted to the desired 100 % filling level via multi-turn trim pot; if this level is exceeded, the signal continuously increases to above 100 %

Measurement begins at 0 % at specified dimension above bottom edge of probe; below this level, the signal remains at 0 %, "negative" filling level is not possible

or

Measurement begins at 0 % where filling level from bottom edge of probe = immersion depth of the float

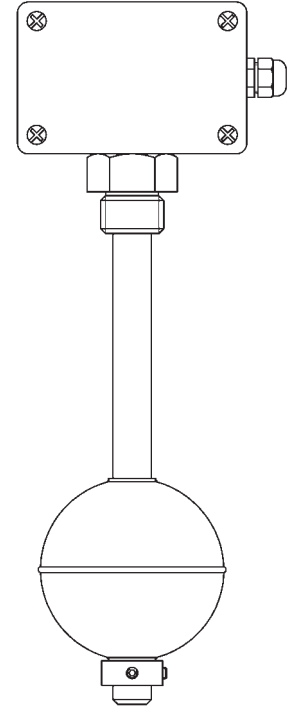

horizontal (standard)

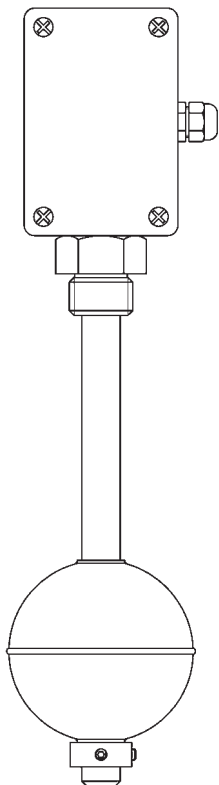

vertical

Jola - TSK 4-20/... liquid level indicator

Consisting of

- sensor:

Potentiometer adjusted by float via a transmission chain.

- transmitter:

A 2-wire module in the terminal box of the liquid level indicator converts the potentiometer position into a load-independent current signal 4...20 mA.

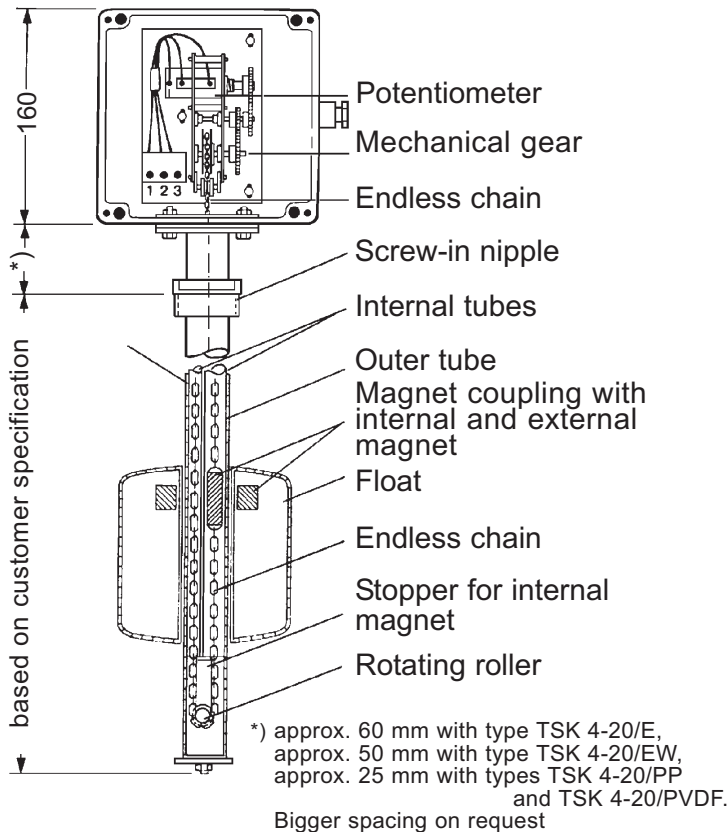

Mode of operation

A float with built-in permanent magnet moves up and down on the probe tube of the TSK 4-20/... liquid level indicator with the liquid level. Inside the probe tube, there is a second magnet integrated in a circulating endless chain inside the bigger of the two guide tubes. The magnet follows the float magnet and therefore the liquid level. This in turn moves the endless chain, which then acts on a potentiometer via a gear in the terminal box of the TSK 4-20/... liquid level indicator. This results in continuous height-proportional resistance measurement.

The change in resistance resulting from the upward and downward motion of the float is recorded via a transmitter in the terminal box of the TSK 4-20/... liquid level indicator and converted into a load-independent current 4 ... 20 mA.

Area of application

The TSK 4-20/... liquid level indicator is designed for use in low-viscosity liquids or liquids with only low solid content in open or closed tanks. It is not suitable for use in liquids that are prone to deposit formation, adhesion or crystallisation which might hinder the movement of the float on the probe tube. It is also not suitable for use in liquids with permanently moving surface and/or on vibrating machines.

Types	Probe tube		Float		Page
	Material	Ext. Ø	Material	Dimensions	
TSK 4-20/E	stainless steel 316 Ti	28 mm	stainless steel 316 Ti	148 mm Ø x 150 mm	5-1-19
TSK 4-20/EW	stainless steel 316 Ti	22 mm	stainless steel 316 Ti	97 mm Ø x 100 mm	5-1-19
TSK 4-20/PP	PP	32 mm	PP	145 mm Ø x 83 mm	5-1-21
TSK 4-20/PVDF	PVDF	32 mm	PVDF	149 mm Ø x 140 mm	5-1-21

Technical data	TSK 4-20/E	TSK 4-20/EW
Sensor	stainless steel 316 Ti	
Probe tube material	stainless steel 316 Ti	
Probe tube diameter	28 mm	22 mm
Probe tube length	according to customer specification taking into account the max. probe tube length	
Max. probe tube length	6,000 mm	3,000 mm
Screw-in nipple	stainless steel 316 Ti, G1	
Float	stainless steel 316 Ti, <u>cylindrical float</u> 148 mm Ø x 150 mm high, up to 5 bar, on request: <u>cylindrical float</u> 240 mm Ø x 190 mm Ø, up to 5 bar, <u>ball float</u> 180 mm Ø, up to 25 bar, <u>oval float</u> 200 mm Ø x 100 mm high, up to 10 bar, (only for specific gravity $\geq 1 \text{ g/cm}^3$)	stainless steel 316 Ti, G1 <u>cylindrical float</u> 97 mm Ø x 100 mm high
Float suitable for use in liquids with a specific gravity	$\geq 0.7 \text{ g/cm}^3$	$\geq 0.8 \text{ g/cm}^3$
Terminal box	glass fibre reinforced polyester, A 113, 160 x 160 x 90 mm, protection class IP 65	
Mounting orientation	vertical	
Temperature application range	from 0°C to + 100°C (inside the terminal box: from 0°C to + 60°C), other temperature application range on request	
Pressure resistance at + 20°C	in line with the float used (see above)	max. 8 bar
Measuring principle	the magnet of the float leads to a change in resistance via a second magnet, a transmission chain, a gear and a potentiometer. This provides a quasi-continuous height-proportional measuring signal	
Measuring precision	continuous depending on the position of the potentiometer	
Transmitter		
Measuring electronics	2 wires (independent of polarity)	
Setting possibility	0 % value not adjustable, 100 % value adjustable via a potentiometer	
Power supply	DC 15 - 30 V (independent of polarity)	
Measuring signal	4 ... 20 mA	
Admiss. load in the current loop	max. 200 ohm at 15 V; max. 900 ohm at 30 V	
Connecting terminals	for max. 2.5 mm ² solid cable or max. 1.5 mm ² flexible cable	
EMC	for interference emission in accordance with the appliance-specific requirements for households, business and commerce as well as small companies, and for interference immunity in accordance with the appliance-specific requirements for industrial companies.	

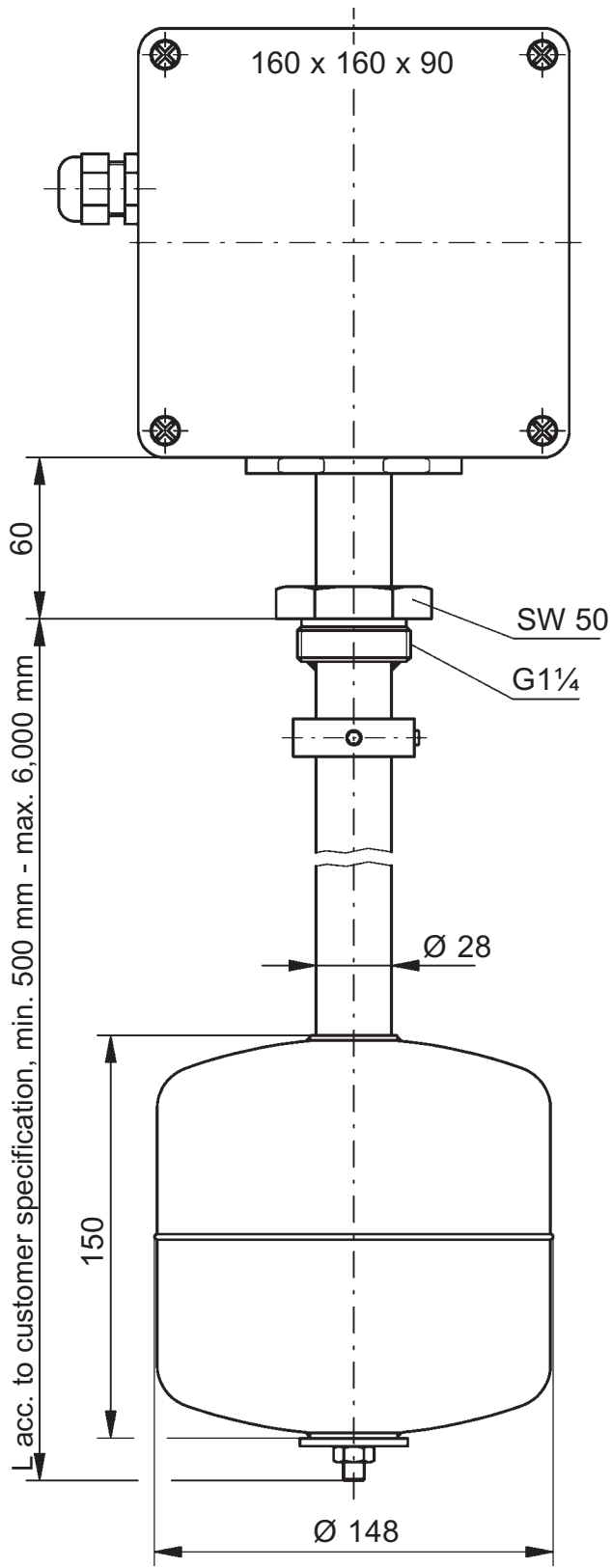

TSK 4-20/E

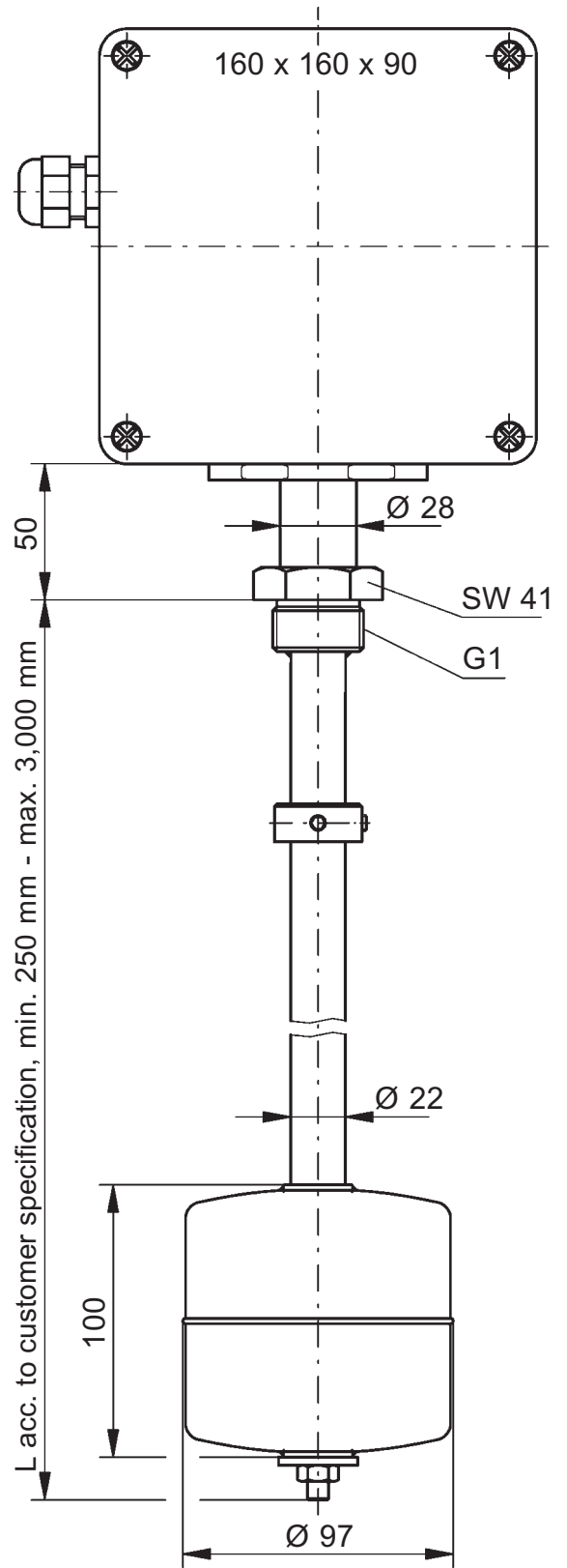

TSK 4-20/EW

Technical data	TSK 4-20/PP	TSK 4-20/PVDF
Sensor		
Probe tube material	PP	PVDF
Probe tube diameter	32 mm	
Probe tube length	according to customer specification taking into account the max. temperature in the tank and the max. probe tube length (see below)	
Max. probe tube length	3,000 mm	
Screw-in nipple	PP, G1½	PVDF, G1½
Float	PP, <u>cylindrical float</u> 145 mm Ø x 83 mm high	PVDF, <u>cylindrical float</u> 149 mm Ø x 140 mm high
Float suitable for use in liquids with a specific gravity	≥ 0.8 g/cm ³	
Terminal box	glass fibre reinforced polyester, A 113, 160 x 160 x 90 mm, protection class IP 65	
Mounting orientation	vertical	
Temperature application range taking into account the probe tube length:		
- up to max. 3,000 mm	from 0°C to + 40°C	from 0°C to + 40°C
- up to max. 2,000 mm	from 0°C to + 60°C	from 0°C to + 60°C
- up to max. 1,500 mm	from 0°C to + 75°C	from 0°C to + 90°C
- up to max. 1,000 mm	from 0°C to + 90°C	from 0°C to + 100°C
	(inside the terminal box: from 0°C to + 60°C)	
Pressure resistance / pressure test	for pressureless applications (pressure test: max. 3 bar at + 20°C)	
Measuring principle	the magnet of the float leads to a change in resistance via a second magnet, a transmission chain, a gear and a potentiometer. This provides a quasi-continuous height-proportional measuring signal	
Measuring precision	continuous depending on the position of the potentiometer	
Transmitter		
Measuring electronics	2 wires (independent of polarity)	
Setting possibility	0 % value not adjustable, 100 % value adjustable via a potentiometer	
Power supply	DC 15 - 30 V (independent of polarity)	
Measuring signal	4 ... 20 mA	
Admiss. load in the current loop	max. 200 ohm at 15 V; max. 900 ohm at 30 V	
Connecting terminals	for max. 2.5 mm ² solid cable or max. 1.5 mm ² flexible cable	
EMC	for interference emission in accordance with the appliance-specific requirements for households, business and commerce as well as small companies, and for interference immunity in accordance with the appliance-specific requirements for industrial companies.	

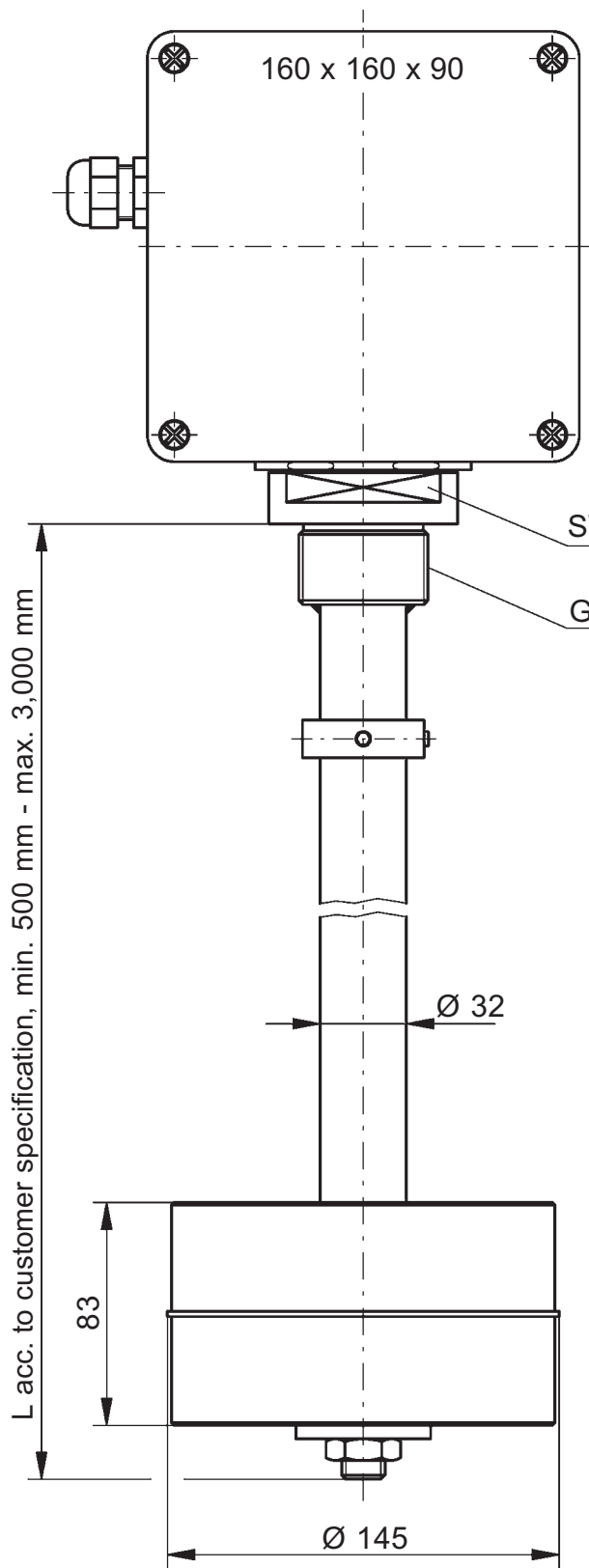

TSK 4-20/PP

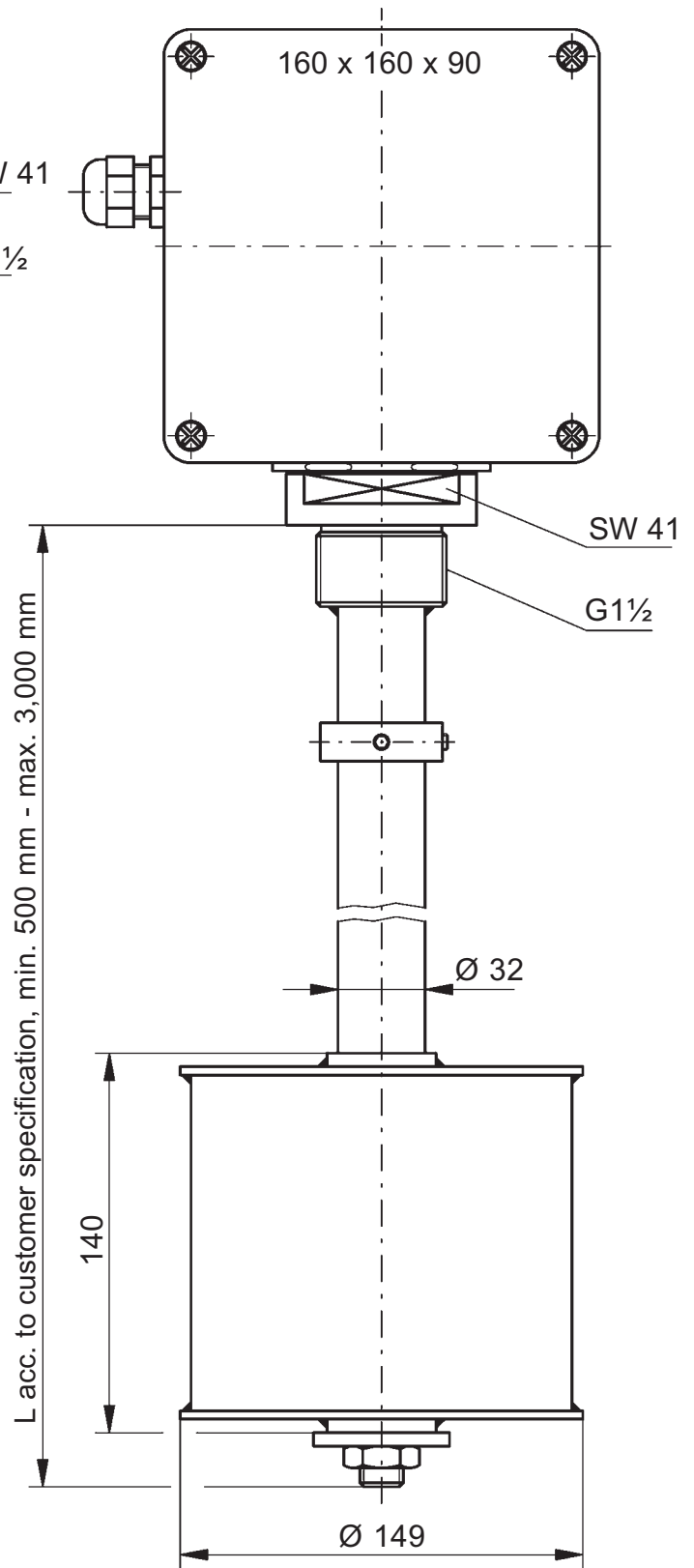

TSK 4-20/PVDF

Jola- SKG 420 switching unit for signalling 1 limit level, with integrated liquid level indicator feed, for analogue current loop signal 4 ... 20 mA

Application example

The SKG 420 switching unit feeds the liquid level indicator in 2-wire design for a current loop signal 4 ... 20 mA. The liquid level-proportional current signal (4 ... 20 mA) of the liquid level indicator can be displayed via an ammeter if desired. The SKG 420 switching unit changes its switching status if the actual value rises above or falls below the set minimum or maximum value.

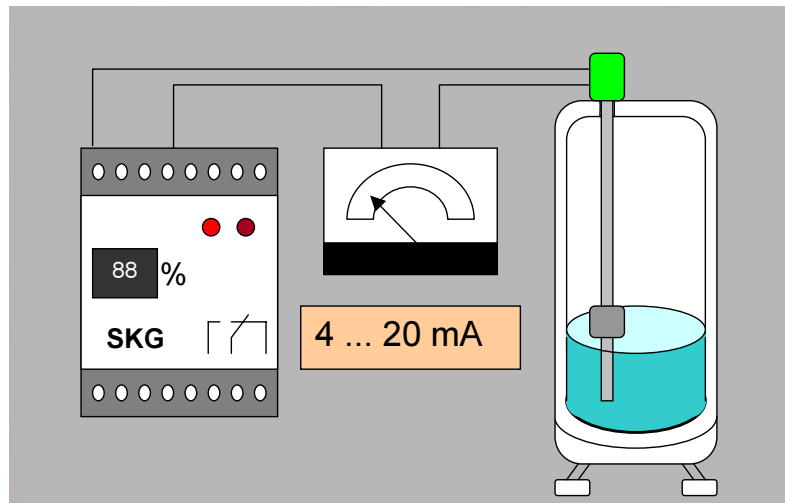

Switching unit for U-bar or surface mounting, with connection terminals on top, 1 encoder switch and integrated liquid level indicator feed.

This switching unit is designed for switch cabinet installation or mounting in an appropriate protective housing and may therefore not be installed in other locations. It is only suitable for use in clean environments.

Mode of operation:

The SKG 420 is suitable for feeding a 2-wire liquid level indicator for a current loop signal 4 ... 20 mA. The liquid level indicator is connected to terminals + 24 V and I of the SKG 420.

Additional SKG 420, ZKG 420 or VKG 420-1020 switching units can be integrated in the current loop (terminals I and GND).

The encoder switch can be used to set a limit value in the range from 0 to 99%.

If the input value is below the set limit value, the output relay is energised.

If the input value is above the set limit value, the output relay is not energised (quiescent current principle).

The switching status of the output relay is indicated by LEDs.

Technical data**SKG 420 for current input 4 ... 20 mA
or for voltage input 2 ... 10 V**

Alternative supply voltages
(AC versions:
terminals 15 and 16;
DC versions:
- terminal 15: —,
- terminal 16: +)

- AC 230 V (supplied if no other supply voltage is specified in the order) or
- AC 240 V or
- AC 115 V or
- AC 24 V or
- DC 24 V or } in these two cases, the unit must only be
- DC 12 V or } connected to a low safety voltage which corresponds to the safety regulations relating to the application
- further supply voltages on request

Power input

approx. 3 VA

Liquid level indicator feed
(terminals 4+ and 5-)

DC 24 V, current rating max. 25 mA,
short-term short circuit protected

**Input signal
(terminals 1, 2, 3)**

4 ... 20 mA or 2 ... 10 V

terminal 1 = I = + input current
terminal 2 = GND = - input
terminal 3 = U = + input voltage

Input resistance

current input = 50 ohm, voltage input = 200 kohm

Switching point setting

via encoder switch in the range from 0 to 99 %

Switching status indicators

2 red LED to indicate if the limit value is exceeded or not achieved

Reproducibility

approx. 1 %

**Controlled circuit
(terminals 9, 10, 11)**

1 single-pole potential-free changeover contact based on the quiescent current principle; working current principle on request.
The output relay is energised if the input value is lower than the set limit value.
The output relay is not energised if the input value is higher than the set limit value.

Switching voltage

max. AC 250 V

Switching current

max. AC 4 A

Switching capacity

max. 500 VA

Housing

insulating material, 75 x 55 x 110 mm

Connection

terminals on top of housing

Protection class

IP 20

Mounting

clip attachment for U-bar to DIN 46277 and EN 50022
or fastening via two boreholes

Mounting orientation

any

Temperature application range

- 20°C to + 60°C

EMC

for interference emission in accordance with the appliance-specific requirements for households, business and commerce as well as small companies, and for interference immunity in accordance with the appliance-specific requirements for industrial companies.

Other versions on request.

Jola - ZKG 420 switching unit for level regulation between 2 limit levels, with integrated liquid level indicator feed, for analogue current loop signal 4 ... 20 mA

Application example

The ZKG 420 switching unit feeds the liquid level indicator in 2-wire design for a current loop signal 4 ... 20 mA. The liquid level-proportional current signal (4 ... 20 mA) of the liquid level indicator can be displayed via an ammeter if desired. The ZKG 420 switching unit serves as a two-point control device between two set limit values. One possible application is a level regulation between 2 limit levels for a rainwater tank to secure water reserves by feeding in fresh water.

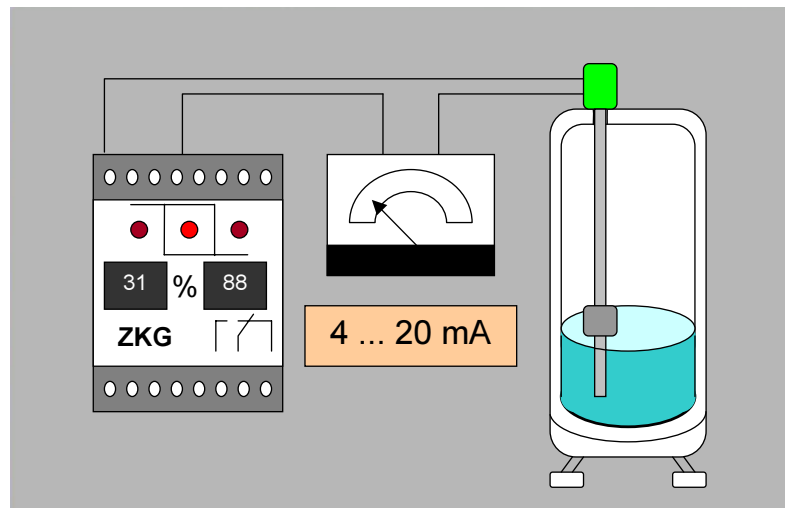

Switching unit for U-bar or surface mounting, with connection terminals on top, 2 encoder switches and integrated liquid level indicator feed.

This switching unit is designed for switch cabinet installation or mounting in an appropriate protective housing and may therefore not be installed in other locations. It is only suitable for use in clean environments.

Mode of operation:

The ZKG 420 is suitable for feeding a 2-wire liquid level indicator for a current loop signal 4 ... 20 mA. The liquid level indicator is connected to terminals + 24 V and I of the ZKG 420.

Additional SKG 420, ZKG 420 or VKG 420-1020 switching units can be integrated in the current loop (terminals I and GND).

The 2 encoder switches can be used to set a limit value for the switch-on point as well as a limit value for the switch-off point in the range from 0 to 99% (two-point control).

If the input value is below the set lower limit value, the output relay is energised.

If the input value is above the set top limit value, the output relay is not energised (quiescent current principle).

Values above the two switching points and energisation of the output relay are indicated by three LEDs.

Technical data**ZKG 420 for current input 4 ... 20 mA
or for voltage input 2 ... 10 V**

Alternative supply voltages
(AC versions:
terminals 15 and 16;
DC versions:
- terminal 15: -,
- terminal 16: +)

- AC 230 V (supplied if no other supply voltage is specified in the order) or
- AC 240 V or
- AC 115 V or
- AC 24 V or
- DC 24 V or } in these two cases, the unit must only be
- DC 12 V or } connected to a low safety voltage which corresponds to the safety regulations relating to the application
- further supply voltages on request approx. 3 VA

Power input
Liquid level indicator feed
(terminals 4+ and 5-)

DC 24 V, current rating max. 25 mA,
short-term short circuit protected

**Input signal
(terminals 1, 2, 3)**

4 ... 20 mA or 2 ... 10 V / 0 ... 20 mA or 0 ... 10 V

terminal 1 = I = + input current

terminal 2 = GND = - input

terminal 3 = U = + input voltage

Input resistance
Switching point setting

current input = 50 ohm, voltage input = 200 kohm
per limit value via 1 encoder switch in the range from
0 to 99 %

Switching status indicators

left LED:
lit when input value is higher than limit value set on the left
middle LED:
lit when output relay is in self-hold (not energised)
right LED:
lit when input value is higher than limit value set on right

Level regulation between
2 limit levels

Between set lower and upper limit (both encoding switches can be set either as lower or upper limit value). The difference between lower and upper limit value must be at least 1 %. The input signal must be able to fall below the lower limit value by at least 1 % and exceed the upper limit value by at least 1 %
approx. 1 %

Reproducibility
**Controlled circuit
(terminals 9, 10, 11)**

1 single-pole potential-free changeover contact with self-hold based on the quiescent current principle; working current principle on request.

The output relay is energised if the input value is lower than the set lower limit value.

The output relay is not energised if the input value is higher than the set top limit value.

Switching voltage
Switching current
Switching capacity
Housing
Connection
Protection class
Mounting

max. AC 250 V

max. AC 4 A

max. 500 VA

insulation material, 75 x 55 x 110 mm
terminals on top of housing

IP 20

clip attachment for U-bar to DIN 46277 and
EN 50022 or fastening via two boreholes

any

Mounting orientation
Temperature application
range
EMC

- 20°C to + 60°C

for interference emission in accordance with the appliance-specific requirements for households, business and commerce as well as small companies, and for interference immunity in accordance with the appliance-specific requirements for industrial companies.

Jola - VKG 420-1020 switching unit for comparison of 2 signals, with integrated liquid level indicator feed, for analogue standard signals 0 ... 20 mA, 4 ... 20 mA or 0 ... 10 V, 2 ... 10 V



Switching unit for U-bar or surface mounting, with connection terminals on top, 1 encoder switch and integrated feed of 2 liquid level indicators.

This switching unit is designed for switch cabinet installation or mounting in an appropriate protective housing and may therefore not be installed in other locations. It is only suitable for use in clean environments.

Mode of operation

The VKG 420-1020 is suitable for feeding two 2-wire liquid level indicators for a current loop signal 4 ... 20 mA. The liquid level indicators are connected to terminals + 24 V and I1 resp. I2 of the VKG 420-1020. Additional SKG 420, ZKG 420 or VKG 420-1020 switching units can be integrated in the current loop (terminals I and GND).

If the input value is a current 0 ... 20 mA or 4 ... 20 mA, the input terminals I and GND are to be used.

If the input value is a voltage 0 ... 10 V or 2 ... 10 V, the input terminals U and GND are to be used.

Two input channels, A and B, are available for comparison of the magnitude of two measuring signals.

Either current or voltage signals can be fed into the two input channels independently of one another.

Both input channels have the same reference ground (GND).

The encoder switch (digits 0 to 9) on the front can be used to adjust the hysteresis from +/- 1% to +/- 10% of the signal range width (0 ... 10 V or 0 ... 20 mA) or from 1.25% to 12.5% of the signal range width (2 ... 10 V or 4 ... 20 mA).

If the input value at input channel A is higher than the input value at input channel B, the output relay is energised (A > B) and the left-hand red LED lights up.

If the input value at input channel A is lower than the input value at input channel B, the output relay is not energised (A < B) and the right-hand red LED lights up. In other words, it is always the LED of the channel with the larger input signal that lights up.

Application example

The VKG 420-1020 switching unit feeds 2 liquid level indicators in 2-wire design for a current loop signal 4 ... 20 mA. The filling level-proportional current signals (4 ... 20 mA) of the liquid level indicators can be displayed on 2 ammeters if desired. The VKG 420-1020 switching unit serves to compare two analogue standard signals. One possible application would be the evenly balanced emptying of two rainwater tanks with at the beginning different levels.

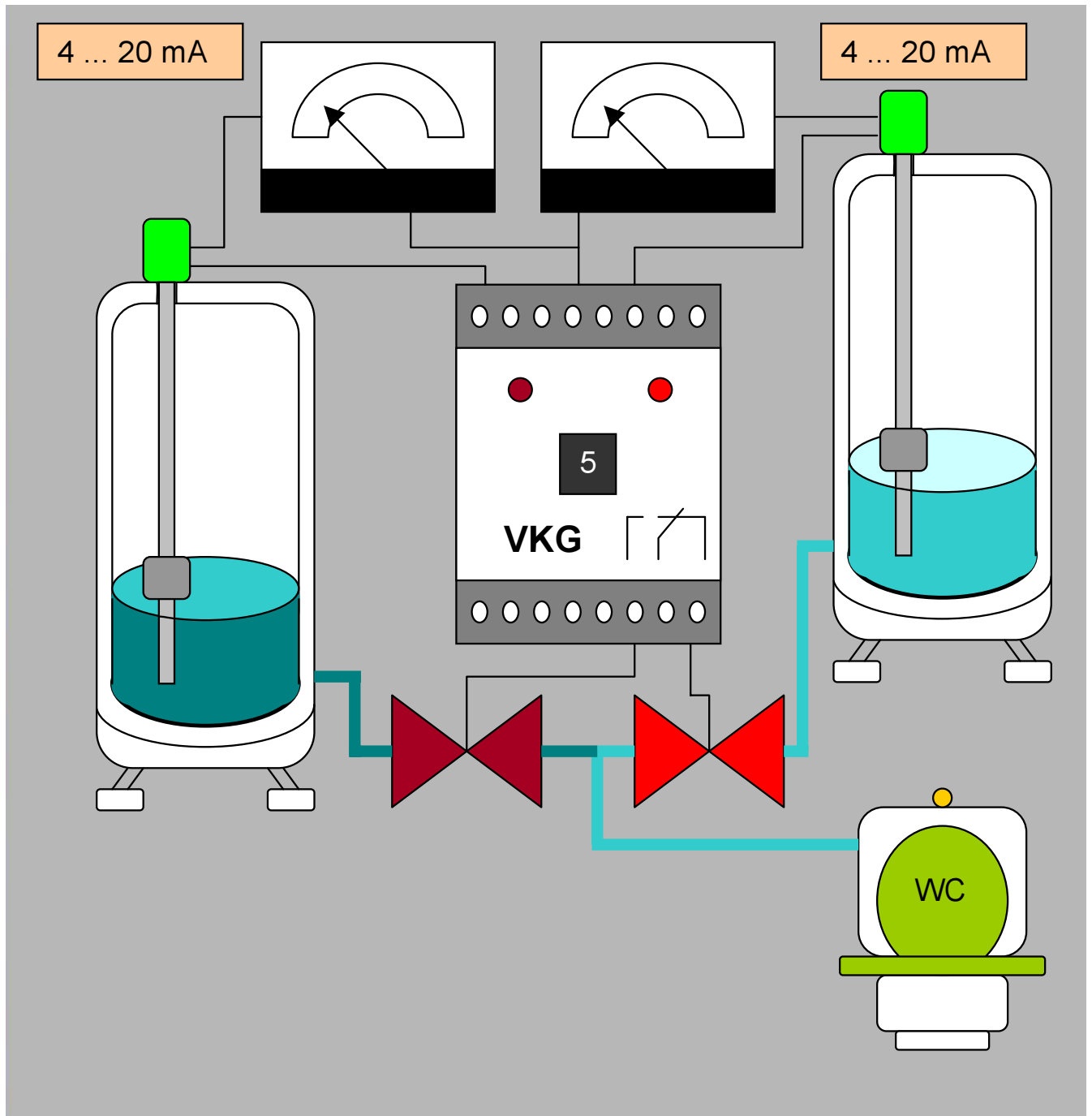

Technical data**VKG 420-1020**

Alternative supply voltages
(AC versions:
terminals 15 and 16;
DC versions:
- terminal 15: -,
- terminal 16: +)

- AC 230 V (supplied if no other supply voltage is specified in the order) or
- AC 240 V or
- AC 115 V or
- AC 24 V or
- DC 24 V or } in these two cases, the unit must only be
- DC 12 V or } connected to a low safety voltage which corresponds to the safety regulations relating to the application
- further supply voltages on request

Power input

approx. 3 VA

Liquid level indicator feed
(terminals 4+ and 5-)

DC 24 V, current rating max. 25 mA,
short-term short circuit protected

Input signals

(channel A : term. 1, 2, 3 ;
channel B : term. 6, 7, 8)

0 ... 20 mA or 4 ... 20 mA or 0 ... 10 V or 2 ... 10 V

terminals 1, 6 = I = + input current

terminals 2, 7 = GND = - input

terminals 3, 8 = U = + input voltage

Input resistance

current input = 50 ohm, voltage input = 200 kohm

Switching hysteresis setting

via encoder switch in the range from +/- 1% to +/- 10%
of the signal range width (0 ... 10 V or 0 ... 20 mA)
or from 1,25% to 12,5% of the signal range width
(2 ... 10 V or 4 ... 20 mA)

Switching status indicators

left LED: lit when input value A is higher than input value B
right LED: lit when input value A is lower than input value B

Signal comparison

the difference between the two signal values must at least
correspond to the hysteresis width set via the encoder
switch to ensure that the output relay switches over

**Controlled circuit
(terminals 9, 10, 11)**

**1 single-pole potential-free changeover contact.
The output relay is energised if input value A is higher
than input value B. The output relay is not energised if
input value A is lower than input value B.**

Switching voltage

max. AC 250 V

Switching current

max. AC 4 A

Switching capacity

max. 500 VA

Housing

insulating material, 75 x 55 x 110 mm

Connection

via terminals on top of housing

Protection class

IP 20

Mounting

clip attachment for U-bar to DIN 46277 and
EN 50022 or fastening via two boreholes

Mounting orientation

any

Temperature application
range

- 20°C to + 60°C

EMC

for interference emission in accordance with the appliance-
specific requirements for households, business and
commerce as well as small companies, and for
interference immunity in accordance with the appliance-
specific requirements for industrial companies

Jola - Indicating instrument for current 4 ... 20 mA

This indicating instrument is designed for switch cabinet installation or mounting in an appropriate protective housing and may therefore not be installed in other locations. It is only suitable for use in clean environments.



Technical data

	Q 10 - 420
Input signal	4 ... 20 mA
Scale	0 - 100 %
Front dimensions	96 x 96 mm
Cutout dimensions	92 x 92 mm
Installation depth	61 mm
Indicating accuracy	class 1.5
Temperature application range	from - 15°C to + 40°C

Connecting diagram for TSQ 4-20/... or TSK 4-20/... with Q10-420 and SKG 420 or ZKG 420 and VKG 420-1020

